

Solmec
SINCE 1960

EXP 5035



Maintenance

The large bonnets can be easily opened to allow major maintenance operations to be carried out quickly and efficiently, while preserving operator safety.

The intervals of maintenance have been extended to reduce maintenance time, increase machine availability and reduce operating costs.

Slew ring, boom, stick, and rams are lubricated by a centralized automatic system with a 4 kg tank, while cab parallelogram elevating system doesn't require any lubrication due to special bushes.

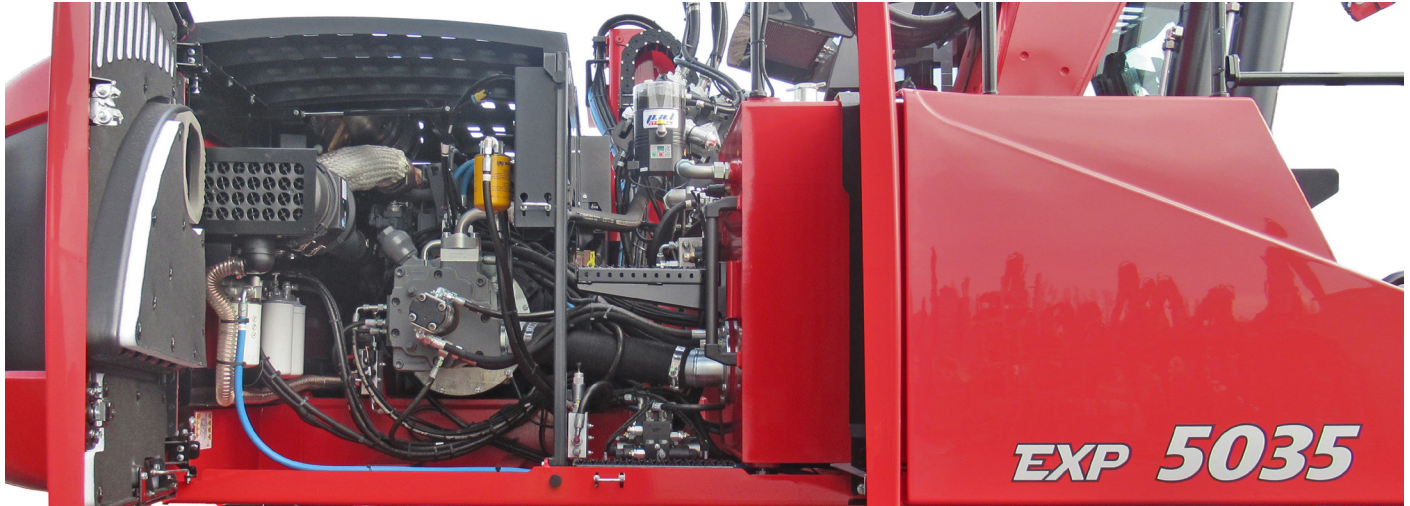

Aluminium large meshes radiators, with automatic thermostatic reversible fan increase cleanness of the radiators and reduce Diesel consumption.

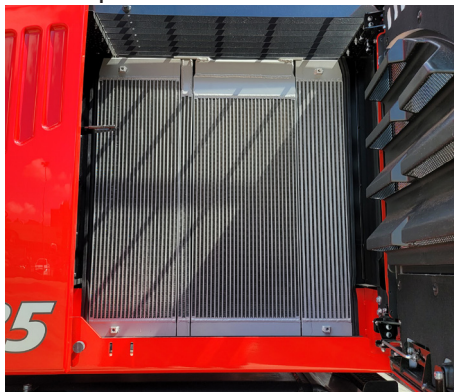

Air cleaner with self-cleaning micro-cyclones vacuum system standard included: lower maintenance time and costs, higher efficiency for the air filter, optimum working conditions for the Diesel engine.

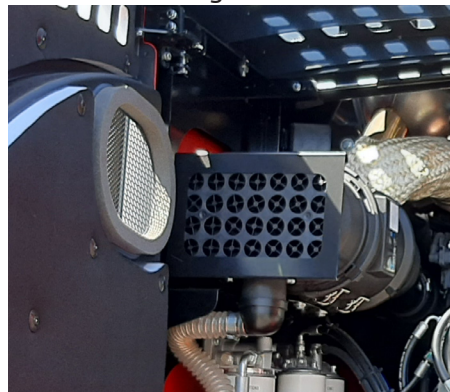

Centralized automatic greasing system (as standard), to make easier service operations.



Automatic greasing of the slewing ring teeth.

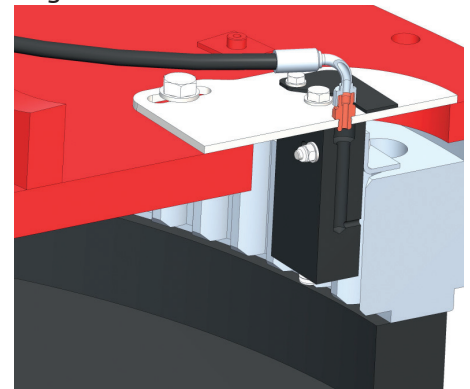

The self-lubricating anti-friction bushes consist of a glass fibre load-bearing layer and a machinable sliding layer of fibre material with epoxy resin with PTFE.



Eco-friendly choice: No lubricant.

No daily maintenance:

Reduced interventions and maintenance downtime for lubrication/greasing.

Cost savings:

No lubrication system. Less grease costs.

Used in heavy duty environments:

No starting problems, corrosive environments, humid, cold climates.

Safety

Solmec has always been committed to work safety. The “OWD” (Overload Warning Device), antirollover system, controls the load handled by the machine and stops the movements when it exceeds the maximum load allowed, authorizing only the movements that permit to be brought back the load to the safety position. The operator presence system allows the use of machine controls only if the operator is seated in the driver’s seat with the left armrest lowered. Non-slip steps and side handrails make it easier for the operator to get on and off the machine.

Wide steps standard included, for a safer and easier access on the machine and to the main maintenance and refuelling areas.

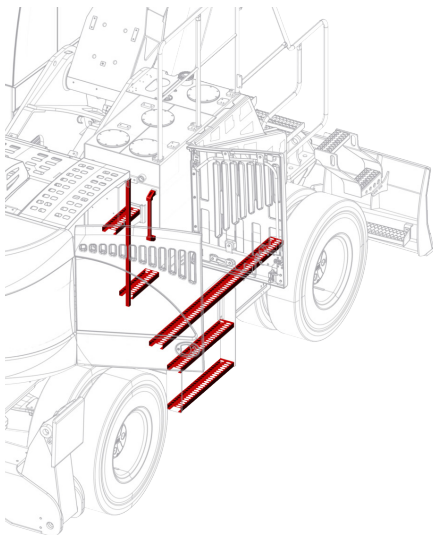
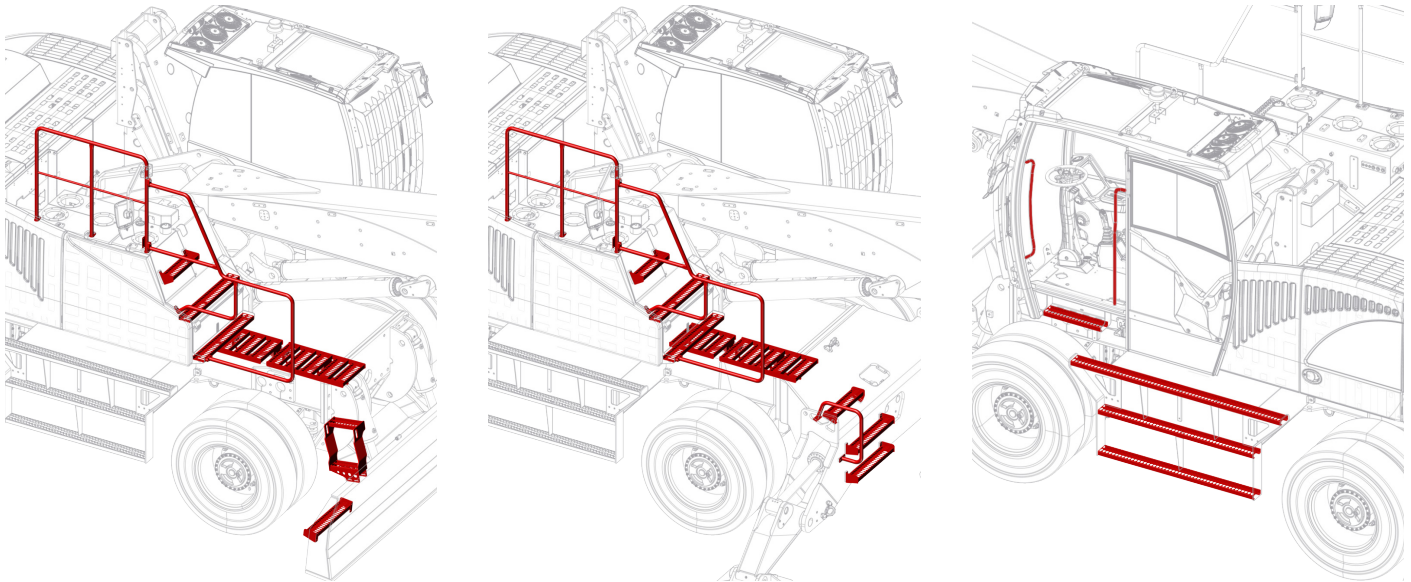

Operators cabin with hydraulic parallelogram elevation has a operator’s eye 5,3 m high reach.

It is possible, as option, to arrive to 6,1 m. operator’s eye

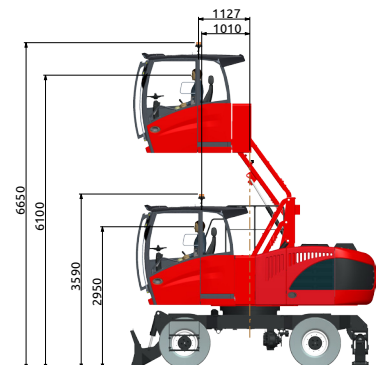
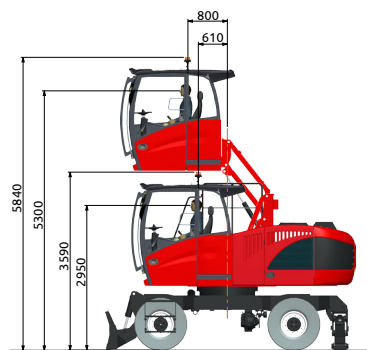

Double rear mirrors with wide angle view on right and left side.

As option: rear camera with 7” color display into the cabin. Possibility to fit a camera on the right side and/or under the cab (or kit 3 cameras).



Performance

For over 60 years, Solmec produces material handling machines for scraps metal and waste recycling industry, for steel mills, for port and rail unloading, for sawmills, tanneries and car demantlers. The new spacious cabin, equipped with every comfort, guarantees a pleasant and efficient working environment. The large windows in addition to the elevation cab allow a perfect view of the working area and ensure to the operator a driving in perfect safety .



Complete dashboard with 7 "color screen and reminder of maintenance intervals.

The on-board computer also displays the «OWD» (Overload Warning Device) functions to keep the load being handled under control at all times.

New electronic joysticks with proportional rollers for precise control of the bucket rotation, the front blade and the outriggers.

For better visibility, steering on joysticks is available as option.

SOLIDA - Solmec Link Data

SOLIDA (Solmec Link Data) is a tool completely integrate on the material handler monitoring system and it permit to check:

- the position
- the working hours
- fuel consumption
- downtime machine
- possible error messages
- etc...

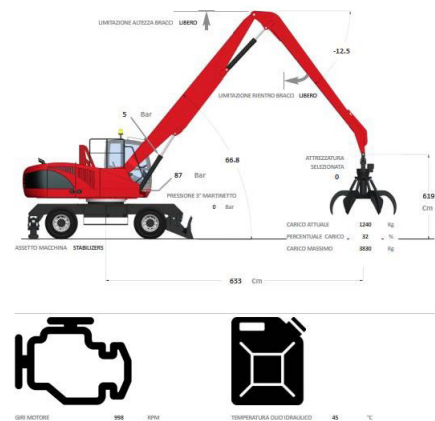

these data are viewed trough the web interface.

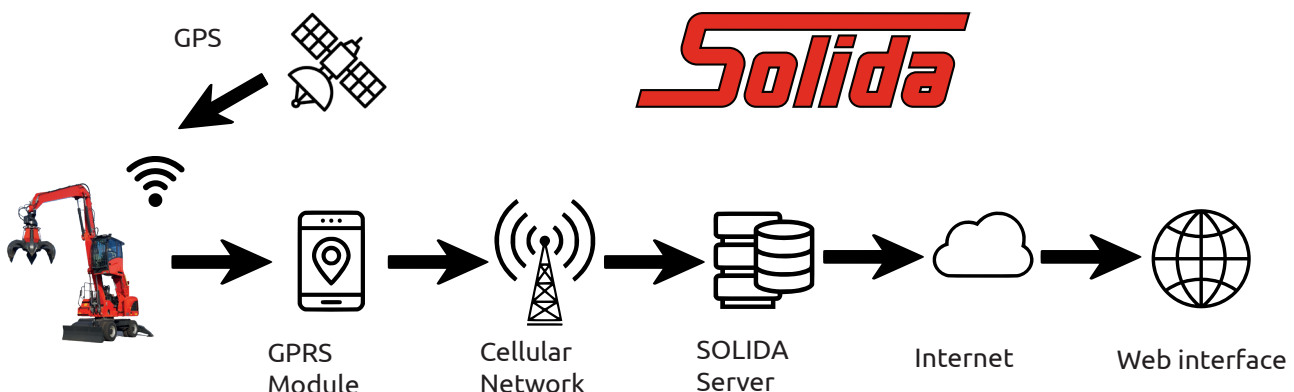

Comfort



Easy access button panel for headlights, windshield wipers and bluetooth® radio.



Automatic air conditioned as standard.



3 air conditioning fans separated from the main radiators for a more efficient cooling system.



Roll-up sun blind and wiper on the roof



Front-mounted roller sun blind.



Driver's cab with large glass surfaces and left sliding side window.



Adjustable steering column ...



... for a comfortable driving position.



3 Standard LED headlights on cab.

WORKING DIAGRAM

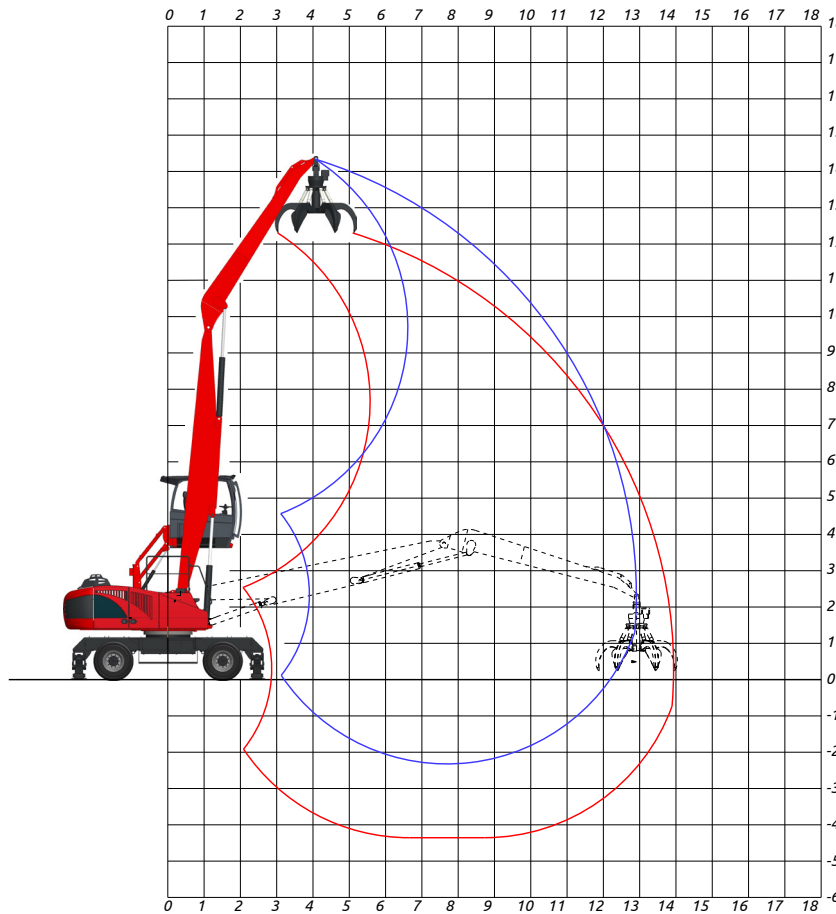

DF13:
Straight boom
7,40 m

Industrial stick
5,50 m

OPERATING WEIGHT:

35.600 kg (Standard)
38.100 kg ("HD")

OPERATING WEIGHT WITH 4 OUTRIGGERS,
 SOLID RUBBER TYRES,
 STRAIGHT BOOM 7,40 m,
 INDUSTRIAL STICK 5,50 m,
 RV 550 ORANGE PEEL GRAB WITH ROTATOR.

DIMENSIONS

Standard undercarriage

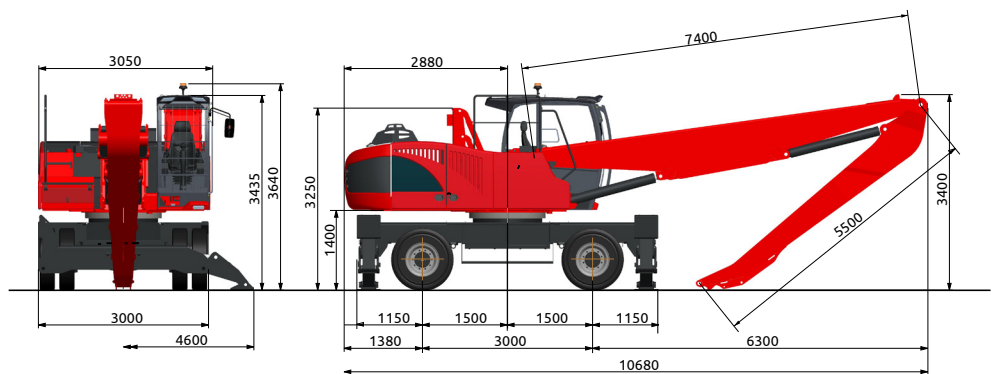

"HD" undercarriage

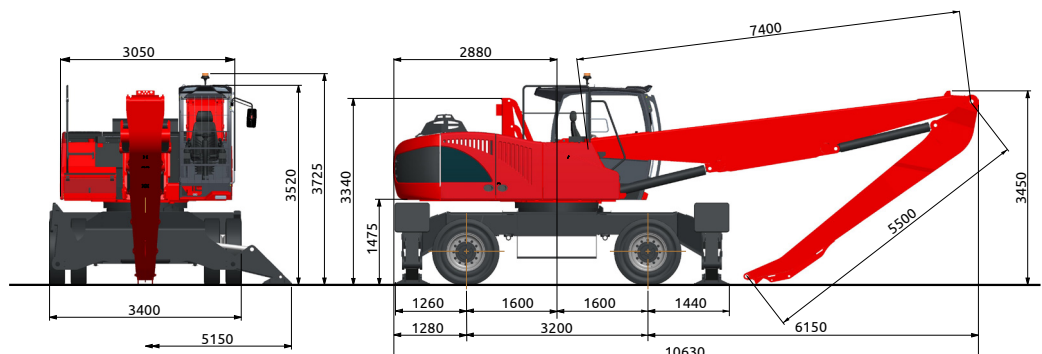

LIFTING CAPACITIES TONS STANDARD UNDERCARRIAGE "DF13"

LIFTING RANGE (m)

| HEIGHT METERS | CONF. | 5,0 | | 6,0 | | 8,0 | | 10,0 | | 12,0 | | 12,9 | |
|---------------|-------|--------|---------------|--------|---------------|-------|--------------|-------|--------------|-------|--------------|-------|--------------|
| | | ○ | ⊙ | ○ | ⊙ | ○ | ⊙ | ○ | ⊙ | ○ | ⊙ | ○ | ⊙ |
| 12,0 | ○○ | | | | | 6,58* | 4,38 | | | | | | |
| | ┌┐ | | | | | 6,58* | 6,58* | | | | | | |
| | └└ | | | | | 6,58* | 6,58* | | | | | | |
| 10,0 | ○○ | | | | | 7,05 | 4,58 | 4,71 | 3,06 | | | | |
| | ┌┐ | | | | | 7,87* | 7,87* | 5,84* | 5,80 | | | | |
| | └└ | | | | | 7,87* | 7,87* | 5,84* | 5,84* | | | | |
| 8,0 | ○○ | | | | | 7,00 | 4,55 | 4,79 | 3,12 | | | | |
| | ┌┐ | | | | | 7,90* | 7,90* | 6,69* | 5,86 | | | | |
| | └└ | | | | | 7,90* | 7,90* | 6,69* | 6,69* | | | | |
| 6,0 | ○○ | | | 9,90* | 6,86 | 6,73 | 4,37 | 4,68 | 3,04 | 3,38 | 2,20 | | |
| | ┌┐ | | | 9,90* | 9,90* | 8,17* | 8,17* | 6,76* | 5,77 | 5,61* | 4,29 | | |
| | └└ | | | 9,90* | 9,90* | 8,17* | 8,17* | 6,76* | 6,76* | 5,61* | 5,21 | | |
| 4,0 | ○○ | 12,61 | 8,20 | 9,63 | 6,26 | 6,29 | 4,09 | 4,46 | 2,90 | 3,31 | 2,15 | | |
| | ┌┐ | 13,47* | 13,47* | 11,27* | 11,27* | 8,55* | 7,83 | 6,86* | 5,59 | 5,54* | 4,23 | | |
| | └└ | 13,47* | 13,47* | 11,27* | 11,27* | 8,55* | 8,55* | 6,86* | 6,79 | 5,54* | 5,15 | | |
| 2,0 | ○○ | 10,96 | 7,13 | 8,59 | 5,59 | 5,81 | 3,77 | 4,22 | 2,74 | 3,20 | 2,08 | 2,86 | 1,86 |
| | ┌┐ | 14,68* | 14,68* | 12,00* | 11,31 | 8,78* | 7,43 | 6,84* | 5,40 | 5,30* | 4,15 | 4,41* | 3,74 |
| | └└ | 14,68* | 14,68* | 12,00* | 12,00* | 8,78* | 8,78* | 6,84* | 6,59 | 5,30* | 5,07 | 4,41* | 4,41* |
| 0 | ○○ | 7,62* | 6,46 | 7,86 | 5,11 | 5,42 | 3,52 | 4,02 | 2,61 | 3,13 | 2,03 | | |
| | ┌┐ | 7,62* | 7,62* | 11,71* | 10,67 | 8,54* | 7,11 | 6,48* | 5,24 | 4,68* | 4,09 | | |
| | └└ | 7,62* | 7,62* | 11,71* | 11,71* | 8,54* | 8,54* | 6,48 | 6,42 | 4,68* | 4,68* | | |
| -2,0 | ○○ | | | 7,56 | 4,91 | 5,22 | 3,39 | | | | | | |
| | ┌┐ | | | 9,97* | 9,97* | 7,46* | 6,94 | | | | | | |
| | └└ | | | 9,97* | 9,97* | 7,46* | 7,46* | | | | | | |

LIFTING CAPACITIES TONS "HD" UNDERCARRIAGE "DF13"

LIFTING RANGE (m)

| HEIGHT METERS | CONF. | 5,0 | | 6,0 | | 8,0 | | 10,0 | | 12,0 | | 12,9 | |
|---------------|-------|--------|---------------|--------|---------------|-------|--------------|-------|--------------|-------|--------------|-------|--------------|
| | | ○ | ⊙ | ○ | ⊙ | ○ | ⊙ | ○ | ⊙ | ○ | ⊙ | ○ | ⊙ |
| 12,0 | ○○ | | | | | 6,58* | 5,75 | | | | | | |
| | ┌┐ | | | | | 6,58* | 6,58* | | | | | | |
| | └└ | | | | | 6,58* | 6,58* | | | | | | |
| 10,0 | ○○ | | | | | 7,87* | 5,96 | 5,84* | 4,09 | | | | |
| | ┌┐ | | | | | 7,87* | 7,87* | 5,84* | 5,84* | | | | |
| | └└ | | | | | 7,87* | 7,87* | 5,84* | 5,84* | | | | |
| 8,0 | ○○ | | | | | 7,90* | 5,93 | 6,37 | 4,14 | | | | |
| | ┌┐ | | | | | 7,90* | 7,90* | 6,69* | 6,69* | | | | |
| | └└ | | | | | 7,90* | 7,90* | 6,69* | 6,69* | | | | |
| 6,0 | ○○ | | | 9,90* | 8,91 | 8,17* | 5,74 | 6,26 | 4,07 | 4,64 | 3,01 | | |
| | ┌┐ | | | 9,90* | 9,90* | 8,17* | 8,17* | 6,76* | 6,76* | 5,61* | 5,57 | | |
| | └└ | | | 9,90* | 9,90* | 8,17* | 8,17* | 6,76* | 6,76* | 5,61* | 5,61* | | |
| 4,0 | ○○ | 13,47* | 10,89 | 11,27* | 8,30 | 8,39 | 5,45 | 6,04 | 3,92 | 4,56 | 2,97 | | |
| | ┌┐ | 13,47* | 13,47* | 11,27* | 11,27* | 8,55* | 8,55* | 6,86* | 6,86* | 5,54* | 5,51 | | |
| | └└ | 13,47* | 13,47* | 11,27* | 11,27* | 8,55* | 8,55* | 6,86* | 6,86* | 5,54* | 5,54* | | |
| 2,0 | ○○ | 14,68* | 9,77 | 11,69 | 7,60 | 7,89 | 5,13 | 5,79 | 3,76 | 4,46 | 2,90 | 4,02 | 2,61 |
| | ┌┐ | 14,68* | 14,68* | 12,00* | 12,00* | 8,78* | 8,78* | 6,84* | 6,84* | 5,30* | 5,30* | 4,41* | 4,41* |
| | └└ | 14,68* | 14,68* | 12,00* | 12,00* | 8,78* | 8,78* | 6,84* | 6,84* | 5,30* | 5,30* | 4,41* | 4,41* |
| 0 | ○○ | 7,62* | 7,62* | 10,92 | 7,10 | 7,49 | 4,87 | 5,58 | 3,63 | 4,38 | 2,85 | | |
| | ┌┐ | 7,62* | 7,62* | 11,71* | 11,71* | 8,54* | 8,54* | 6,48* | 6,48* | 4,68* | 4,68* | | |
| | └└ | 7,62* | 7,62* | 11,71* | 11,71* | 8,54* | 8,54* | 6,48* | 6,48* | 4,68* | 4,68* | | |
| -2,0 | ○○ | | | 9,97* | 6,90 | 7,28 | 4,74 | | | | | | |
| | ┌┐ | | | 9,97* | 9,97* | 7,46* | 7,46* | | | | | | |
| | └└ | | | 9,97* | 9,97* | 7,46* | 7,46* | | | | | | |

○ LIFTING CAPACITIES ON 360° WITHOUT SAFETY FACTOR ⊙ LIFTING CAPACITIES ON 360° ACCORDING WITH ISO 10567 * = HIDRAULIC
LIMIT LIFTING CAPACITIES ARE ON HOOK WITHOUT GRABS, MACHINE STATIC, LEVEL SOLID GROUND, WITH AXLE LOCKED.

WORKING DIAGRAM

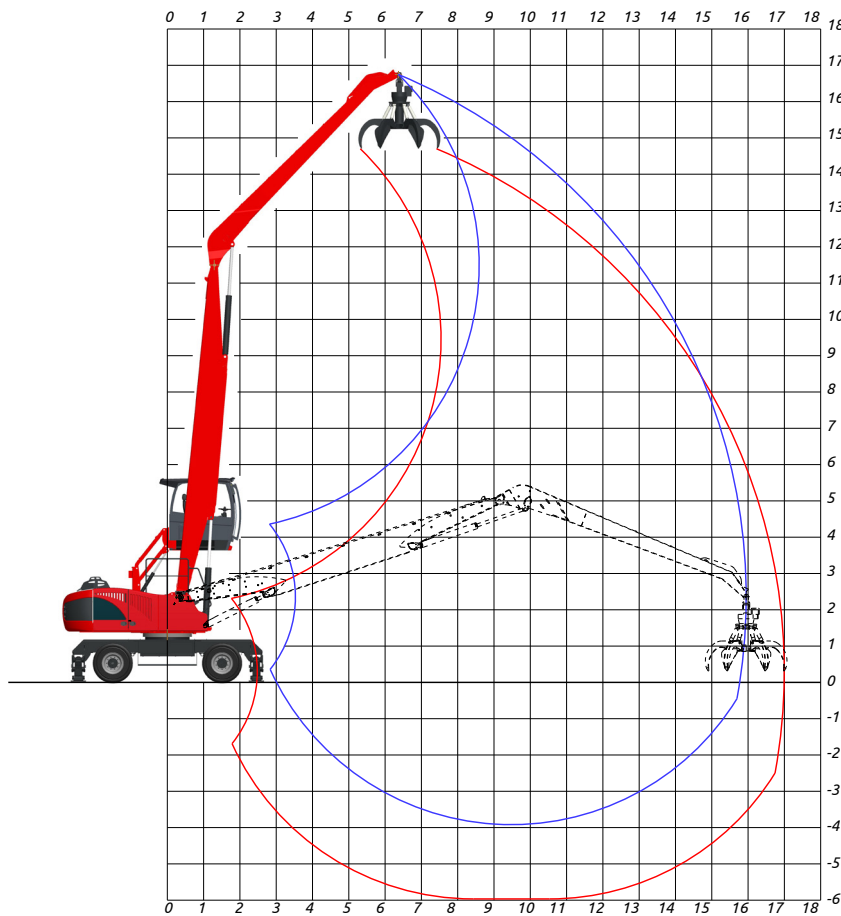

DF16:
Straight boom
9,20 m

Industrial stick
7,30 m

OPERATING WEIGHT:

37.400 kg (Standard)
39.900 kg ("HD")

OPERATING WEIGHT WITH 4 OUTRIGGERS,
 SOLID RUBBER TYRES,
 STRAIGHT BOOM 9,20 m,
 INDUSTRIAL STICK 7,30 m,
 RV 550 ORANGE PEEL GRAB WITH ROTATOR.

DIMENSIONS

Standard undercarriage

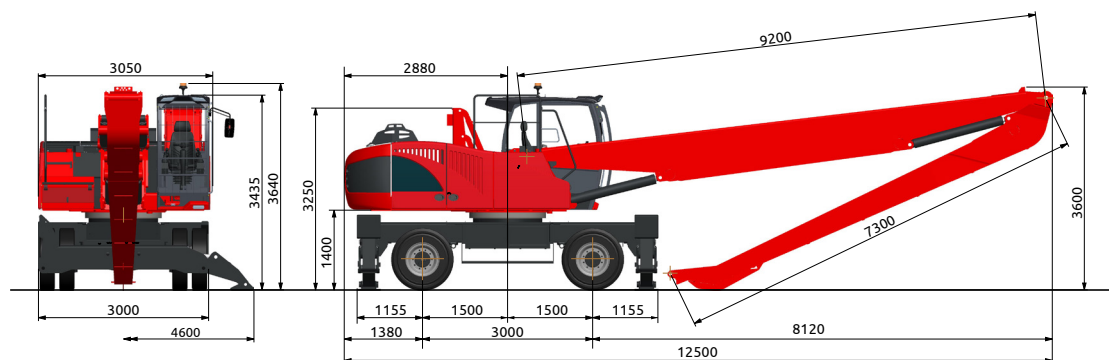

"HD" undercarriage

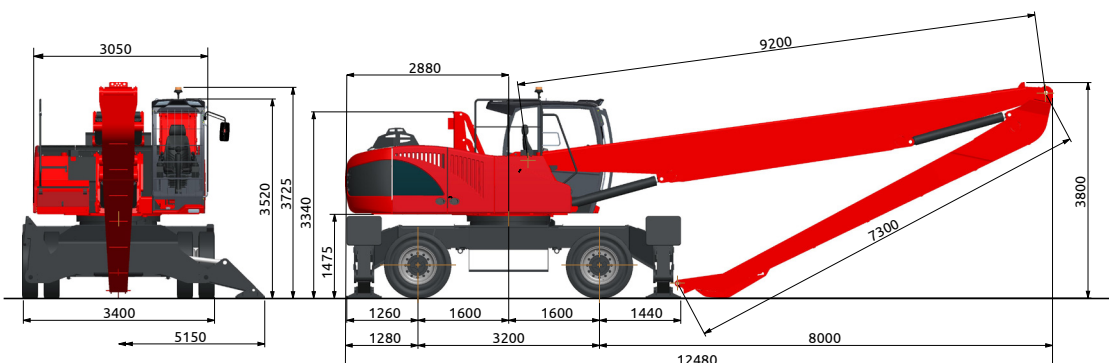

LIFTING CAPACITIES TONS STANDARD UNDERCARRIAGE "DF16"

LIFTING RANGE (m)

| HEIGHT METERS | CONF. | 4,5 | | 7,0 | | 9,5 | | 12,0 | | 14,5 | | 16,0 | |
|---------------|-------|--------|--------|-------|-------|-------|-------|-------|-------|-------|------|-------|------|
| | | ○ | ⊙ | ○ | ⊙ | ○ | ⊙ | ○ | ⊙ | ○ | ⊙ | ○ | ⊙ |
| 15,0 | ┌┐ | | | | | 4,40* | 4,40* | | | | | | |
| | └└ | | | | | 4,40* | 4,40* | | | | | | |
| 12,5 | ┌┐ | | | | | 5,84* | 5,84* | 4,10* | 4,10* | | | | |
| | └└ | | | | | 5,84* | 5,84* | 4,10* | 4,10* | | | | |
| 10,0 | ┌┐ | | | | | 5,87* | 5,87* | 4,80* | 4,39 | | | | |
| | └└ | | | | | 5,87* | 5,87* | 4,80* | 4,80* | | | | |
| 7,5 | ┌┐ | | | | | 6,00* | 6,00* | 4,83* | 4,27 | 3,93* | 2,99 | | |
| | └└ | | | | | 6,00* | 6,00* | 4,83* | 4,83* | 3,93* | 3,71 | | |
| 5,0 | ┌┐ | 7,56* | 7,56* | 8,40* | 8,40* | 6,21* | 5,96 | 4,87* | 4,05 | 3,87 | 2,90 | | |
| | └└ | 7,56* | 7,56* | 8,40* | 8,40* | 6,21* | 6,21* | 4,87* | 4,87* | 3,89* | 3,62 | | |
| 2,5 | ┌┐ | 10,46* | 10,46* | 8,91* | 8,55 | 6,36* | 5,42 | 4,86* | 3,78 | 3,70 | 2,78 | 3,06* | 2,34 |
| | └└ | 10,46* | 10,46* | 8,91* | 8,91* | 6,36* | 6,36* | 4,86* | 4,70 | 3,76* | 3,49 | 3,06* | 2,97 |
| 0 | ┌┐ | 3,02* | 3,02* | 8,79* | 7,56 | 6,22* | 4,94 | 4,65* | 3,54 | 3,43* | 2,66 | | |
| | └└ | 3,02* | 3,02* | 8,79* | 8,79* | 6,22* | 6,22 | 4,65* | 4,45 | 3,43* | 3,37 | | |
| -2,5 | ┌┐ | | | 7,64* | 7,07 | 5,55* | 4,65 | 4,05* | 3,38 | | | | |
| | └└ | | | 7,64* | 7,64* | 5,55* | 5,55* | 4,05* | 4,05* | | | | |

LIFTING CAPACITIES TONS "HD" UNDERCARRIAGE "DF16"

LIFTING RANGE (m)

| HEIGHT METERS | CONF. | 4,5 | | 7,0 | | 9,5 | | 12,0 | | 14,5 | | 16,0 | |
|---------------|-------|--------|--------|-------|-------|-------|-------|-------|-------|-------|-------|-------|-------|
| | | ○ | ⊙ | ○ | ⊙ | ○ | ⊙ | ○ | ⊙ | ○ | ⊙ | ○ | ⊙ |
| 15,0 | ○○ | | | | | 4,40* | 4,4* | | | | | | |
| | ┌┐ | | | | | 4,40* | 4,40* | | | | | | |
| 12,5 | ○○ | | | | | 5,84* | 4,73 | 4,10* | 3,03 | | | | |
| | ┌┐ | | | | | 5,84* | 5,84* | 4,10* | 4,10* | | | | |
| 10,0 | ○○ | | | | | 5,87* | 4,72 | 4,75 | 3,09 | | | | |
| | ┌┐ | | | | | 5,87* | 5,87* | 4,80* | 4,80* | | | | |
| 7,5 | ○○ | | | | | 6,00* | 4,52 | 4,61 | 3,00 | 3,17 | 2,06 | | |
| | ┌┐ | | | | | 6,00* | 6,00* | 4,83* | 4,83* | 3,93* | 3,93* | | |
| 5,0 | ○○ | 7,56* | 7,56* | 8,40* | 6,73 | 6,21* | 4,16 | 4,33 | 2,81 | 3,05 | 1,98 | | |
| | ┌┐ | 7,56* | 7,56* | 8,40* | 8,40* | 6,21* | 6,21* | 4,87* | 4,87* | 3,89* | 3,89* | | |
| 2,5 | ○○ | 10,46* | 10,46* | 8,88 | 5,77 | 5,72 | 3,72 | 3,98 | 2,59 | 2,89 | 1,88 | 2,41 | 1,57 |
| | ┌┐ | 10,46* | 10,46* | 8,91* | 8,91* | 6,36* | 6,36* | 4,86* | 4,86* | 3,76* | 3,76* | 3,06* | 3,06* |
| 0 | ○○ | 3,02* | 3,02* | 7,66 | 4,98 | 5,12 | 3,32 | 3,67 | 2,38 | 2,74 | 1,78 | | |
| | ┌┐ | 3,02* | 3,02* | 8,79* | 8,79* | 6,22* | 6,22* | 4,65* | 4,65* | 3,43* | 3,43* | | |
| -2,5 | ○○ | | | 7,07 | 4,59 | 4,74 | 3,08 | 3,46 | 2,25 | | | | |
| | ┌┐ | | | 7,64* | 7,64* | 5,55* | 5,55* | 4,05* | 4,05* | | | | |

○ LIFTING CAPACITIES ON 360° WITHOUT SAFETY FACTOR ⊙ LIFTING CAPACITIES ON 360° ACCORDING WITH ISO 10567 * = HIDRAULIC
LIMIT LIFTING CAPACITIES ARE ON HOOK WITHOUT GRABS, MACHINE STATIC, LEVEL SOLID GROUND, WITH AXLE LOCKED.

WORKING DIAGRAM

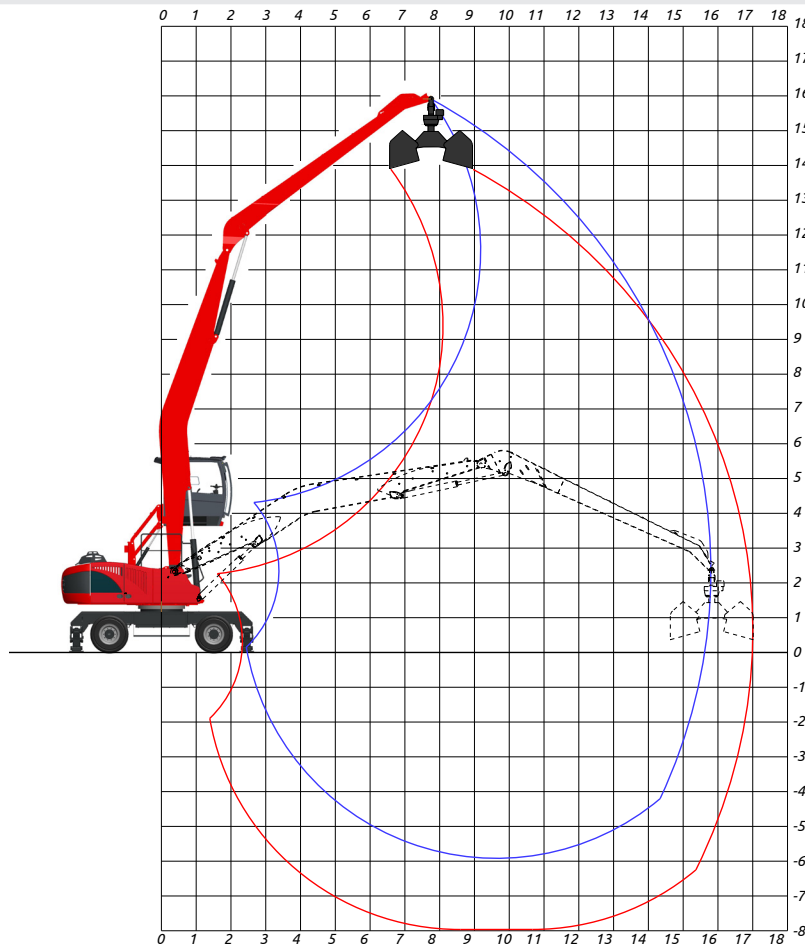

AF16:
Gooseneck boom
9,35 m

Industrial stick
7,30 m

OPERATING WEIGHT:

37.500 kg (Standard)
40.000 kg ("HD")

OPERATING WEIGHT WITH 4 OUTRIGGERS,
SOLID RUBBER TYRES,
GOOSENECK BOOM 9,35 m,
INDUSTRIAL STICK 7,30 m,
R34/1500 CLAMSHELL BUCKET AND ROTATOR.

DIMENSIONS

Standard undercarriage

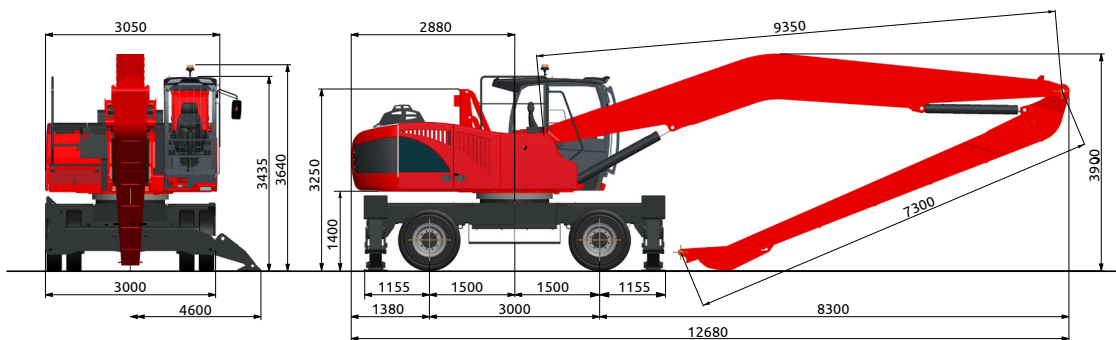

"HD" undercarriage

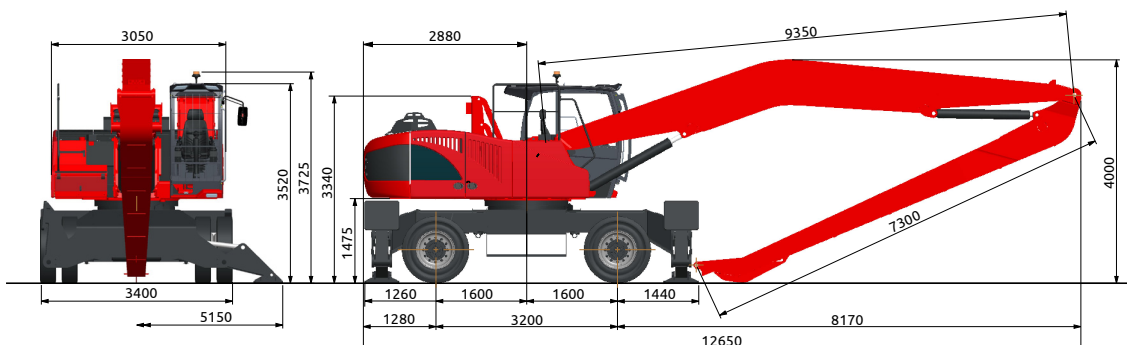

LIFTING CAPACITIES TONS STANDARD UNDERCARRIAGE "AF16"

LIFTING RANGE (m)

| HEIGHT METERS | CONF. | 4,5 | | 7,0 | | 9,5 | | 12,0 | | 14,5 | | 15,8 | |
|---------------|-------|--------|--------|-------|-------|-------|-------|-------|-------|-------|-------|-------|------|
| | | ○ | ⊙ | ○ | ⊙ | ○ | ⊙ | ○ | ⊙ | ○ | ⊙ | ○ | ⊙ |
| 12,5 | ┌┐ | | | | | 4,82* | 4,82* | 3,38* | 3,38* | | | | |
| | └└ | | | | | 4,82* | 4,82* | 3,38* | 3,38* | | | | |
| 10,0 | ┌┐ | | | | | 4,80* | 4,80* | 4,10* | 4,10* | | | | |
| | └└ | | | | | 4,80* | 4,80* | 4,10* | 4,10* | | | | |
| 7,5 | ┌┐ | | | | | 4,99* | 4,99* | 4,17* | 4,17* | 3,58* | 3,06 | | |
| | └└ | | | | | 4,99* | 4,99* | 4,17* | 4,17* | 3,58* | 3,58* | | |
| 5,0 | ┌┐ | | | 7,03* | 7,03* | 5,33* | 5,33* | 4,32* | 4,14 | 3,62* | 2,95 | | |
| | └└ | | | 7,03* | 7,03* | 5,33* | 5,33* | 4,32* | 4,32* | 3,62* | 3,62* | | |
| 2,5 | ┌┐ | 11,78* | 11,78* | 7,88* | 7,88* | 5,70* | 5,51 | 4,47* | 3,84 | 3,64* | 2,80 | | |
| | └└ | 11,78* | 11,78* | 7,88* | 7,88* | 5,70* | 5,70* | 4,47* | 4,47* | 3,64* | 3,52 | | |
| 0 | ┌┐ | 4,00* | 4,00* | 8,36* | 7,59 | 5,92* | 4,98 | 4,53* | 3,55 | 3,54 | 2,66 | 3,20 | 2,40 |
| | └└ | 4,00* | 4,00* | 8,36* | 8,36* | 5,92* | 5,92* | 4,53* | 4,47 | 3,58* | 3,37 | 3,27* | 3,04 |
| -2,5 | ┌┐ | 4,33* | 4,33* | 8,13* | 7,01 | 5,81* | 4,63 | 4,39* | 3,35 | 3,31* | 2,56 | | |
| | └└ | 4,33* | 4,33* | 8,13* | 8,13* | 5,81* | 5,81* | 4,39* | 4,27 | 3,31* | 3,27 | | |
| -5,0 | ┌┐ | | | 7,08* | 6,86 | 5,19* | 4,49 | 3,84* | 3,28 | | | | |
| | └└ | | | 7,08* | 7,08* | 5,19* | 5,19* | 3,84* | 3,84* | | | | |

LIFTING CAPACITIES TONS "HD" UNDERCARRIAGE "AF16"

LIFTING RANGE (m)

| HEIGHT METERS | CONF. | 4,5 | | 7,0 | | 9,5 | | 12,0 | | 14,5 | | 15,8 | |
|---------------|-------|--------|--------|-------|-------|-------|-------|-------|-------|-------|-------|-------|-------|
| | | ○ | ⊙ | ○ | ⊙ | ○ | ⊙ | ○ | ⊙ | ○ | ⊙ | ○ | ⊙ |
| 12,5 | ○○ | | | | | 4,82* | 4,82* | 3,38* | 3,13 | | | | |
| | ┌┐ | | | | | 4,82* | 4,82* | 3,38* | 3,38* | | | | |
| 10,0 | ○○ | | | | | 4,80* | 4,80* | 4,10* | 3,18 | | | | |
| | ┌┐ | | | | | 4,80* | 4,80* | 4,10* | 4,10* | | | | |
| 7,5 | ○○ | | | | | 4,99* | 4,64 | 4,17* | 3,07 | 3,23 | 2,10 | | |
| | ┌┐ | | | | | 4,99* | 4,99* | 4,17* | 4,17* | 3,58* | 3,58* | | |
| 5,0 | ○○ | | | 7,03* | 6,88 | 5,33* | 4,25 | 4,32* | 2,87 | 3,09 | 2,01 | | |
| | ┌┐ | | | 7,03* | 7,03* | 5,33* | 5,33* | 4,32* | 4,32* | 3,62* | 3,62* | | |
| 2,5 | ○○ | 11,78* | 10,74 | 7,88* | 5,84 | 5,70* | 3,77 | 4,02 | 2,61 | 2,89 | 1,88 | | |
| | ┌┐ | 11,78* | 11,78* | 7,88* | 7,88* | 5,70* | 5,70* | 4,47* | 4,47* | 3,64* | 3,64* | | |
| 0 | ○○ | 4,00* | 4,00* | 7,65 | 4,97 | 5,12 | 3,33 | 3,66 | 2,38 | 2,71 | 1,76 | 2,45 | 1,59 |
| | ┌┐ | 4,00* | 4,00* | 8,36* | 8,36* | 5,92* | 5,92* | 4,53* | 4,53* | 3,58* | 3,58* | 3,27* | 3,27* |
| -2,5 | ○○ | 4,33* | 4,33* | 6,95 | 4,51 | 4,68 | 3,04 | 3,40 | 2,21 | 2,59 | 1,68 | | |
| | ┌┐ | 4,33* | 4,33* | 8,13* | 8,13* | 5,81* | 5,81* | 4,39* | 4,39* | 3,31* | 3,31* | | |
| -5,0 | ○○ | | | 6,76 | 4,39 | 4,50 | 2,93 | 3,31 | 2,15 | | | | |
| | ┌┐ | | | 7,08* | 7,08* | 5,19* | 5,19* | 3,84* | 3,84* | | | | |

○ LIFTING CAPACITIES ON 360° WITHOUT SAFETY FACTOR ⊙ LIFTING CAPACITIES ON 360° ACCORDING WITH ISO 10567 * = HIDRAULIC
LIMIT LIFTING CAPACITIES ARE ON HOOK WITHOUT GRABS, MACHINE STATIC, LEVEL SOLID GROUND, WITH AXLE LOCKED.

TECHNICAL DATA EXP 5035

DIESEL ENGINE

TCD 6.1 L6 4V - T5 – Ecological STEP V (CE) - TIER 5 (EPA) with catalytic converter DVERT® and emissions controlled with electronically controlled injection – 6 cylinders in-line – 4 valves – turbocharged with intercooler air/air – common rail – direct injection – water cooled – electric starting system 24 V

| | |
|---------------------|----------------------------|
| Displacement | 6060 cm ³ |
| Power: | 160 kW (218 HP) @ 2000 rpm |
| Max torque: | 900 Nm @ 1450 rpm |
| Tank capacity: | 310 l |
| Urea tank capacity: | 25 l |

HYDRAULIC SYSTEM

Open circuit LOAD SENSING + SYNCRON CONTROL.

Variable displacement axial piston pumps with oil flow adjustment according to the load requirements and with electronic engine speed regulation.

| | |
|-----------------------------|-----------|
| Max. flow: | 540 l/min |
| Max. hydraulic pressure: | 330 bar |
| Hydraulic tank capacity: | 400 l |
| Hydraulic circuit capacity: | 490 l |

Three additional pumps for auxiliary services. Hydraulic oil cooling by means aluminium large mesh heat exchanger combined with engine radiator. Automatic reversible fan for radiator cleaning.

LOAD SENSING system distributor block with simultaneous movements independent of the load and without interaction with synchronised control of all functions.

TRAVEL

Hydrostatic with 4 wheel drive by means of a variable displacement hydraulic axial piston motor mounted on a two speed gearbox hydraulically operated from the cab coupled to the rear axle.

Travel controlled by two separate pedals (one for each travelling direction).

Travel speed (in both directions)

| | |
|----------------|-------------------|
| Working speed: | from 0 to 6 km/h |
| Travel speed: | from 0 to 18 km/h |

Differential axles 3,00 m wide (STD version) or 3,40 m wide (HD Version) with planetary reduction gears on the hubs.

Braking valve integrated on the hydraulic motor.

STEERING

Hydraulic steering system powered by an independent pump. The rear floating axle (STD version) can be hydraulically locked from the cabin in any position. On the HD version the floating axle is the front one.

TYRES

N° 8 solid rubber tyres "SUPERELASTIC" front and rear twinned with rubber spacer rings between tyres.

- 12.00 x 20 (STD version)
- 12.00 x 24 (HD version)

N° 8 front and rear pneumatic twinned "X MINE® D2" tyres

- 12.00 x 20 - 20 PR (STD version)
- 12.00 x 24 - 20 PR (HD version)

BRAKES

SERVICE BRAKES: disk brake on the driveshaft hydraulically operated by the pedal.

PARKING AND EMERGENCY BRAKES: hydraulically released disk-type brake mounted on driveshaft.

SWING SYSTEM

Unlimited rotation in both directions by means of an axial piston hydraulic motor with integrated control valve, splined to a double stage reduction gear with oil bath gears. - Anti-shock valves protect the system and negative parking brake with multiple disks in oil bath.

High diameter double row ball bearing ring with internal teeth. Automatic greasing system

| | |
|--|--------|
| Max rotation speed: | 7 rpm |
| Overall dimensions of rotating turret: | 3,00 m |

OPERATOR'S CAB

Hydraulically operated raising driver's cab mounted on a parallelogram linkage installed on silent block with large windows of tinted heat resistant safety glass; lateral opening window, upper and front glasses with safety grids and wipers. Winter heating and automatic air conditioned installed as standard with adjustable outlet. Radio preset.

Operator's seat with shock absorbing suspension, headrest, lumbar support, belt winder, electric seat heating device and armrests adjustable height and angle. Many possibilities of adjustment according to operator's weight and size.

INSTRUMENTATION

Consists of a coloured display on the dashboard, includes: Engine speed indicator, fuel level, water thermometer, hour counter, hydraulic oil temperature, Volt, oil engine pressure, fuel consumption, load rate of the engine, engine diagnostics, and maintenance program.

Warning lights showing: air cleaner and oil filter clogging, park brake, brakes failure, lights, hydraulic oil low level, urea level, particulate filter regeneration, etc...

CONTROLS

N° 2 electronic controlled joysticks to carry out the main four operations integrated with the armrests.

Electronic proportional rollers for front blade and/or outriggers and telescopic/selector arm and/or grab rotator. Electro hydraulic devices for controlling hydraulic raising of the cab, parking brakes, front axle oscillation lock, gear box.

ARMS

With reach from 13 to 16 metres. possibilità di secondario telescopico o da selezione

SOUND LEVELS

NOISE LIMIT

| | |
|------------|--------------|
| Directive | 2000/14/CE |
| Directive | 2005/88/CE |
| Regulation | 2024/1208/UE |

Sound pressure level at the operator's position: LpA 75 dB (A)

ELECTROMAGNETIC COMPATIBILITY

(Dir. 2014/30/UE) - The machine complies with the specified limits for both emissions and immunity.

OVERLOAD WARNING DEVICE

Machinery Directive 2006/42/EC

Device for monitoring the machine's stability based on the load being handled and its position. It provides hazard warnings via acoustic and visual signals and automatically inhibits machine movements when stability limits are reached. It also displays the lifted load and the maximum permissible load in any working position.

ACCESSORIES

| ACCESSORIES | STANDARD | OPTIONAL |
|---|----------|----------|
| - N° 8 TWINNED SOLID RUBBER TYRES WITH SPACER RUBBER RINGS | • | |
| - "HD" HEAVY DUTY UNDERCARRIAGE | | • |
| - DOUBLE STEERING AXLES | | • |
| - STEERING ON JOYSTICK | | • |
| - SELF LUBRICATING ANTI FRICTION BUSHES ON BLADE, OUTRIGGERS AND PARALLELOGRAM ELEVATING CAB. | • | |
| - MANUAL GREASING SYSTEM FOR THE STEERING AXLE | • | |
| - GEAR AND CARDAN JOINT PROTECTION | | • |
| - WIDENINGS FOR FRONT DOZER BLADE | | • |
| - FAIR ENDING PLATE FOR LOGS | | • |
| - TOWING HOOK | | • |
| - HYDRAULIC PARALLELOGRAM RAISING CAB | • | |
| - HYDRAULIC PARALLELOGRAM RAISING CAB H6000 | | • |
| - OPERATOR SEAT WITH PNEUMATIC SUSPENSION AND HEATING DEVICE | • | |
| - SAFETY SEAT BELT | • | |
| - AUTOMATIC AIR-CONDITIONING SYSTEM | • | |
| - AIR-CONDITIONING FILTER WITH ACTIVATED CHARCOAL | | • |
| - RADIO WITH BLUETOOTH® | | • |
| - WEIGHTING SYSTEM | | • |
| - ANTI-THEFT IMMOBILIZER DEVICE | | • |
| - THREE WORKING LED LIGHTS ON THE CABIN | • | |
| - FRONT AND ROOF WINDOW PROTECTION | • | |
| - TOTAL PROTECTION FOR THE CABIN | | • |
| - AUTOMATIC GREASING SYSTEM FOR THE UPPERSTRUCTURE AND SLEW RING | • | |
| - THERMOSTATIC AUTOMATIC REVERSIBLE FAN | • | |
| - GENERATOR SYSTEM | | • |
| - ADDITIONAL HEATING SYSTEM FOR COLD WEATHER COUNTRIES | | • |
| - CAMERA WITH 7" COLOURED DISPLAY INTO THE CABIN | | • |
| - FUEL AND HYDRAULIC OIL REFILLING PUMPS | | • |
| - SOLIDA REMOTE MONITORING (SOLMEC LINK DATA) | • | |
| - WORKING LIGHTS ON CONTERWEIGHT | • | |
| - TWO WORKING LED LIGHTS ON STICK. | | • |
| - SAFETY VALVES ON ALL CYLINDERS | • | |
| - SELF LEARNING DIPPER PROXIMITY AND HEIGHT LIMITER. | • | |
| - OVERLOAD WARNING DEVICE | • | |
| - LOCKING ARCH FOR LONG LOGS ON BOOM AND/OR STICK | | • |
| - HYDRAULIC SYSTEM FOR SAW | | • |

DOUBLE STEERING AXLE STANDARD UNDERCARRIAGE

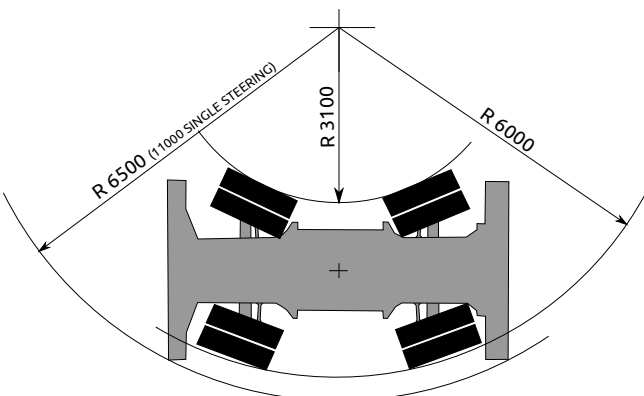

DOUBLE STEERING AXLE HD UNDERCARRIAGE

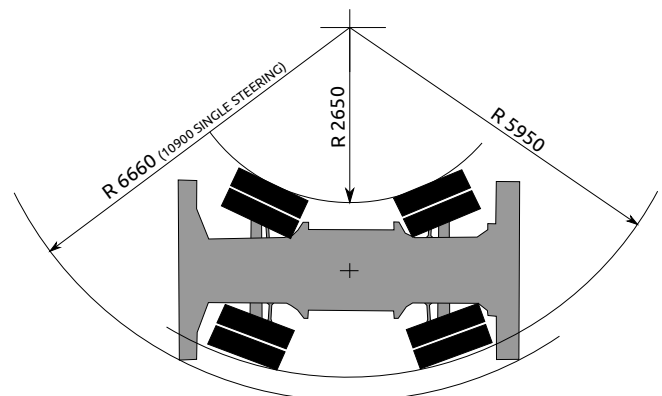

ATTACHMENTS

ORANGE PEEL GRABS FOR SCRAP

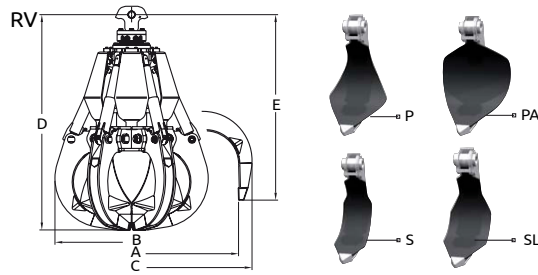

| Model | Capacity | Tines | Weight | Nr of Tines | Dimensions in mm | | | | |
|--------|----------|-----------------|---------|-------------|------------------|------|------|------|------|
| | | | | | A | B | C | D | E |
| RV550 | 550 l | P - PA - S - SL | 1300 kg | 5 | 2000 | 1385 | 2215 | 1810 | 1545 |
| RV550 | 550 l | P - PA - S - SL | 1430 kg | 6 | 2000 | 1385 | 2215 | 1810 | 1545 |
| RV600A | 600 l | P - PA - S - SL | 1500 kg | 5 | 2100 | 1510 | 2290 | 1870 | 1680 |
| RV600A | 600 l | P - PA - S - SL | 1630 kg | 6 | 2100 | 1510 | 2290 | 1870 | 1680 |

LOGS GRAPPLES

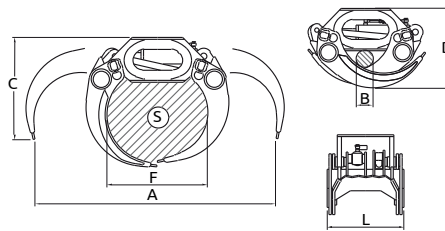

| Model | Area | Lifting capacity | Weight | Dimensions in mm | | | | | |
|-------------|---------------------|------------------|---------|------------------|-----|------|------|------|------|
| | | | | A | B | C | D | L | F |
| SG 720 S-HD | 0,72 m ² | 8000 kg | 526 kg | 2290 | 189 | 1283 | 759 | 521 | - |
| R50/803 | 0,60 m ² | 6000 kg | 1150 kg | 2620 | 200 | 1040 | 940 | 1080 | 1100 |
| R44/802 | 1,10 m ² | 6000 kg | 1400 kg | 2680 | 340 | 1220 | 1480 | 820 | 1380 |
| R44/900 | 1,45 m ² | 6000 kg | 1500 kg | 2900 | 480 | 1270 | 1620 | 900 | 1650 |

CLAMSHELL BUCKETS

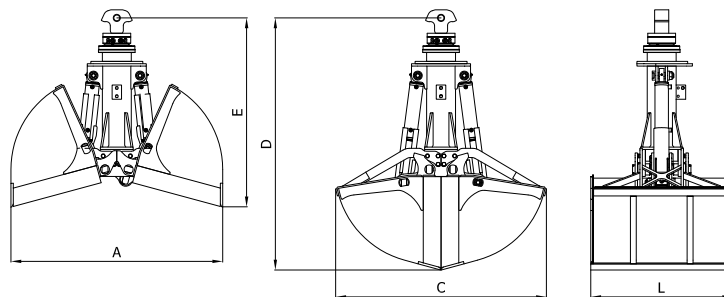

| Model | Capacity | Tine Force | Weight | Dimensions in mm | | | | | |
|-----------|----------|------------|---------|------------------|---|------|------|------|------|
| | | | | A | B | C | D | E | L |
| R34/1000C | 1330 l | 6470 daN | 1320 kg | 2400 | - | 2040 | 2270 | 1420 | 1000 |
| R34/1300C | 1750 l | 6470 daN | 1440 kg | 2400 | - | 2040 | 2270 | 1420 | 1300 |
| R34/1500C | 2000L | 6470 daN | 1520 kg | 2400 | - | 2400 | 2270 | 1420 | 1500 |

ATTACHMENTS

HYDRAULIC ROTATORS

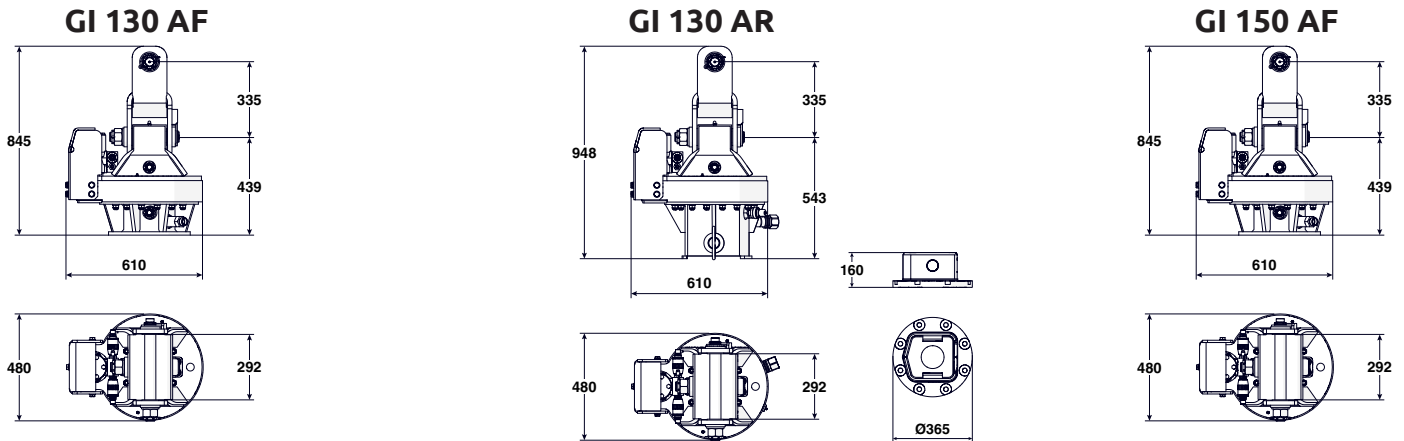

| Model | Lifting capacity | Weight | Torque | Rotation max pressure | Rotation max flow | Attachement max pressure | Attachement max flow |
|-----------|------------------|--------|----------|-----------------------|-------------------|--------------------------|----------------------|
| GI 130 AF | 10 t | 300 kg | 410 daNm | 120 bar | 35 l/min | 320 bar | 250 l/min |
| GI 130 AR | 10 t | 350 kg | 410 daNm | 120 bar | 35 l/min | 320 bar | 250 l/min |
| GI 150 AF | 15 t | 320 kg | 410 daNm | 120 bar | 35 l/min | 320 bar | 250 l/min |

MAGNES

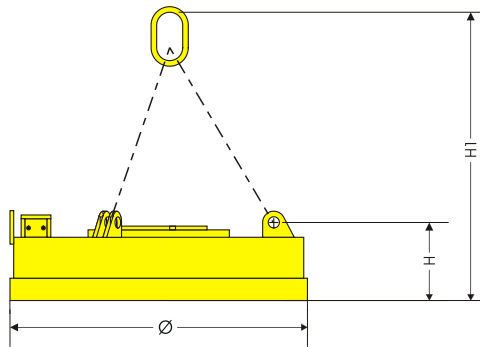

| Model | Absorbed power at 20° | Nominal | Weight | Ø | H | H1 | Hot tear strength (1) Δ= Ø300 | Hot Lifting capacity (2) | | Cast Iron Pigs | Hot Lifting capacity (3) | | |
|----------|-----------------------|---------|--------|------|-----|------|----------------------------------|--------------------------|-----------|----------------|-------------------------------------|-------------------------------------|-------------------------------------|
| | | | | | | | | Slabs or block | Drop Ball | | 3A 2,2 ÷ 2,5 t/m ² | 24 1,9 ÷ 2,0 t/m ² | 40 0,8 ÷ 1,0 t/m ² |
| | kW | Vdc | kg | mm | mm | mm | kg | kg | kg | kg | kg | kg | kg |
| ECS 1050 | 5 | 220 | 600 | 1080 | 215 | 910 | 9500 | 4750 | 1700 | 190 | 170 | 145 | 80 |
| MRS 1050 | 5,5 | 220 | 780 | 1060 | 280 | 975 | 13000 | 6500 | 3000 | 320 | 290 | 280 | 140 |
| ECS 1200 | 7 | 220 | 920 | 1200 | 280 | 1000 | 13000 | 6500 | 3100 | 330 | 315 | 280 | 150 |
| MRS 1250 | 9 | 220 | 1100 | 1250 | 305 | 1000 | 15000 | 7500 | 3500 | 410 | 370 | 360 | 190 |

(1) Determined in accordance with VDE 0580 § 36

(2) Determined after 5 hours and an ambient temperature of 20°C in accordance with VDE 0580 § 36

(3) Determined in accordance with VDE 0580 § 44 2-6



The latest version of the brochure is available on the Solmec website.



Viale delle industrie, 9
45100 ROVIGO - ITALY
phone +39 0425 474833
www.solmec.it
solmec@solmec.it