

**Solmec**  
SINCE 1960



**EXP 5015**

# Maintenance

The large bonnets can be easily opened to allow major maintenance operations to be carried out quickly and efficiently, while preserving operator safety.

The intervals of maintenance have been extended to reduce maintenance time, increase machine availability and reduce operating costs.

Slew ring, boom, stick, and rams are lubricated by a centralized automatic system with a 4 kg tank, while cab parallelogram elevating system doesn't require any lubrication due to special bushes.

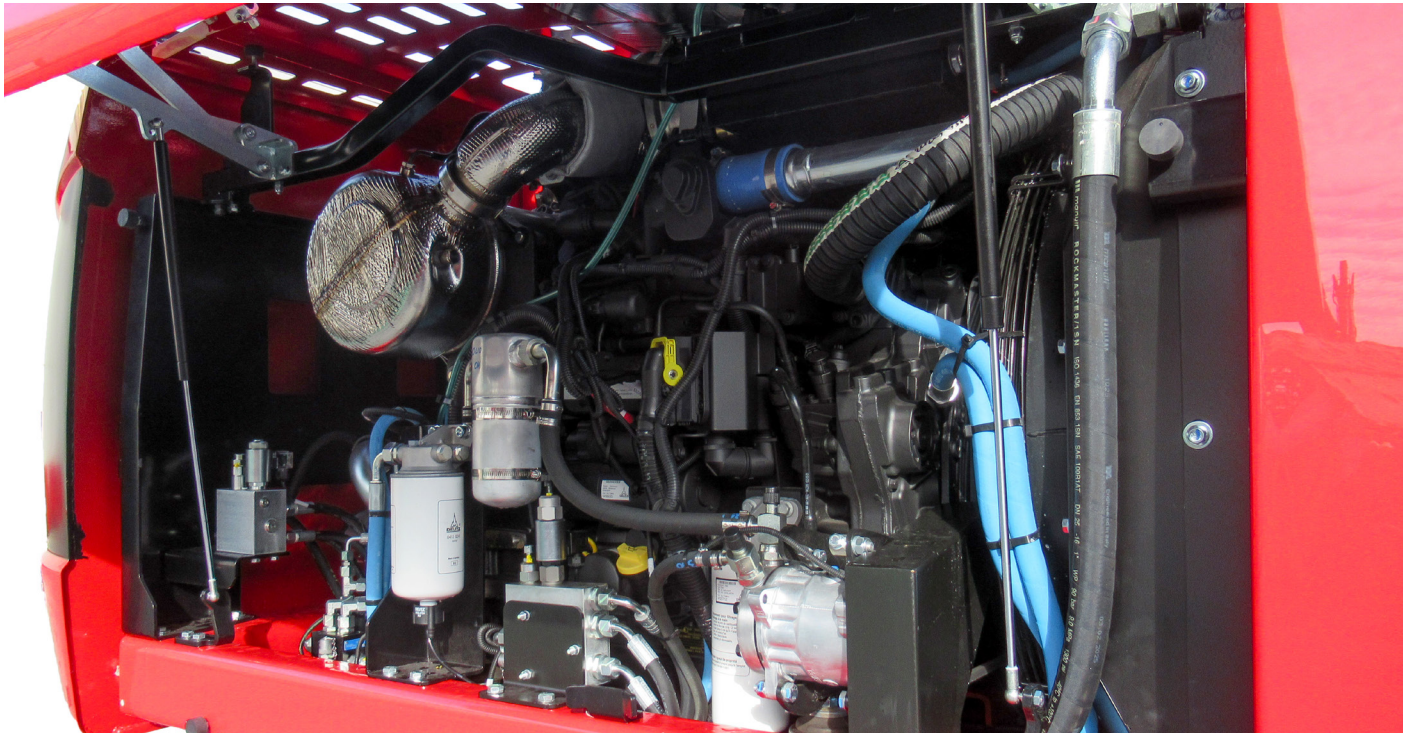

Air cleaner with self-cleaning cyclone. Lower maintenance time and costs, higher efficiency for the air filter, optimum working conditions for the Diesel engine.



Automatic greasing of the slewing ring teeth.

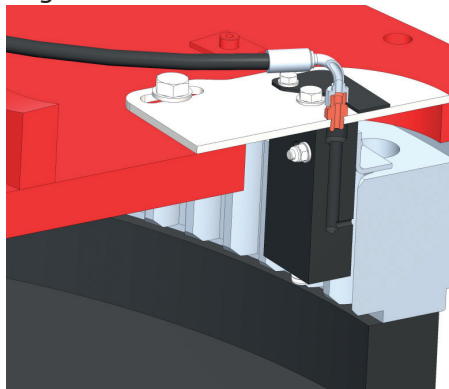

Aluminium large meshes radiators, with automatic thermostatic reversible fan increase cleanliness of the radiators and reduce Diesel consumption.

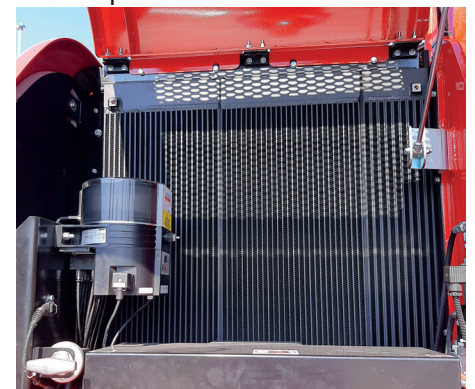

The self-lubricating anti-friction bushes consist of a glass fibre load-bearing layer and a machinable sliding layer of fibre material with epoxy resin with PTFE.

Centralized automatic greasing system (as standard), to make easier service operations.

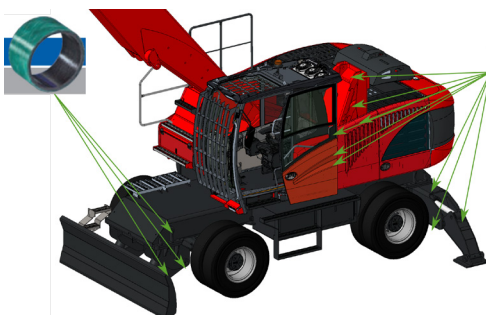

**Eco-friendly choice:** No lubricant.

**No daily maintenance:**

Reduced interventions and maintenance downtime for lubrication/greasing.

**Cost savings:**

No lubrication system. Less grease costs.

**Used in heavy duty environments:**

No starting problems, corrosive environments, humid, cold climates.

# Safety

Solmec has always been committed to work safety. The “OWD” (Overload Warning Device), antirollover system, controls the load handled by the machine and stops the movements when it exceeds the maximum load allowed, authorizing only the movements that permit to be brought back the load to the safety position. The operator presence system allows the use of machine controls only if the operator is seated in the driver’s seat with the left armrest lowered. Non-slip steps and side handrails make it easier for the operator to get on and off the machine.

Wide steps standard included, for a safer and easier access on the machine and to the main maintenance and refuelling areas.

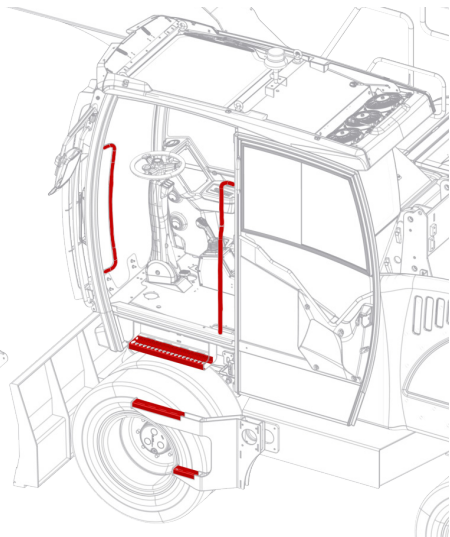
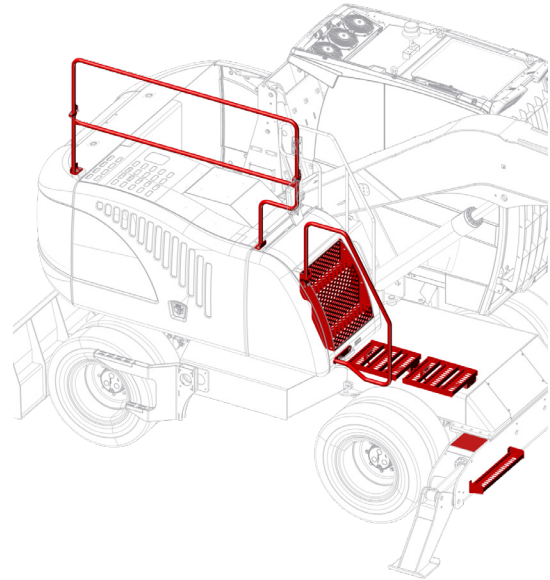
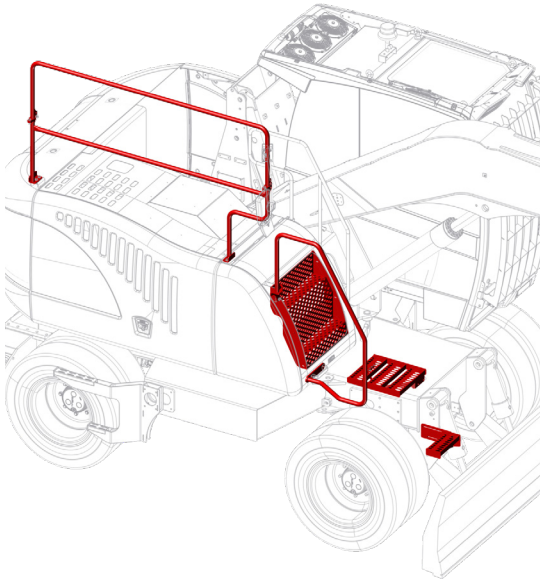

As standard, the operator’s cab with hydraulic vertical elevation provides a 4.0 m operator eye height.

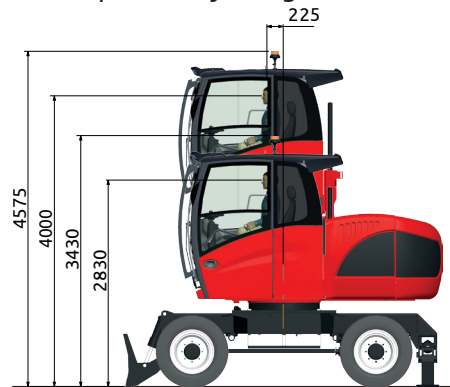

As an option, the operator’s cab with hydraulic parallelogram elevation provides a 4.6 m operator eye height.

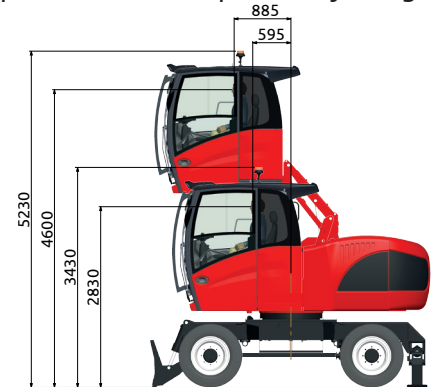

Double rear mirrors with wide angle view on right and left side.

As option: rear camera with 7” color display into the cabin. Possibility to fit a camera on the right side and/or under the cab (or kit 3 cameras).





# Comfort



Easy access button panel for headlights, windshield wipers and bluetooth® radio.



Automatic air conditioned as standard.



3 air conditioning fans separated from the main radiators for a more efficient cooling system.



Roll-up sun blind and wiper on the roof



Front-mounted roller sun blind.



Driver's cab with large glass surfaces and left sliding side window.



Adjustable steering column ...



... for a comfortable driving position.



3 Standard LED headlights on cab.

## WORKING DIAGRAM

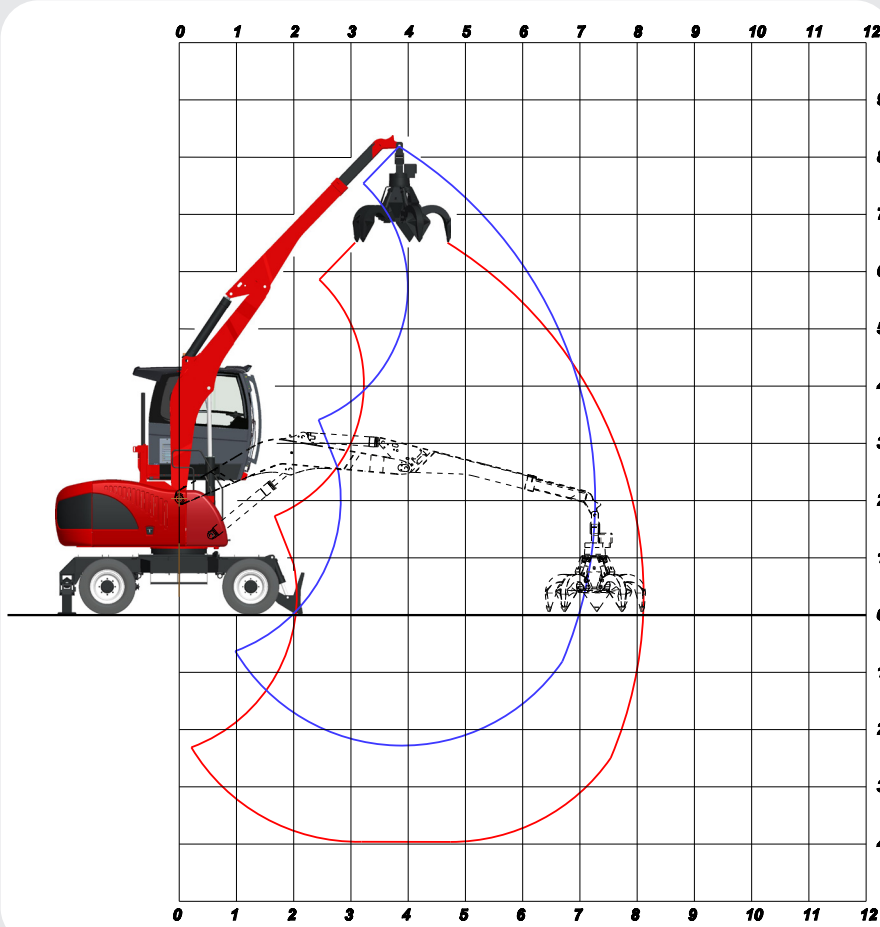

**AT7:**  
Gooseneck boom  
4,00 m

Telescopic stick  
2,50 - 3,40 m

**OPERATING WEIGHT:**

**17.700 kg**

OPERATING WEIGHT WITH FRONT BLADE,  
REAR OUTRIGGERS, SOLID RUBBER TYRES,  
GOOSENECK BOOM 4,00 m,  
TELESCOPIC STICK,  
RV 320 ORANGE PEEL GRAB WITH ROTATOR.

## LIFTING CAPACITIES TONS

LIFTING RANGE (m)

HEIGHT METERS	CONF.	3,0		4,5		6,0		7,3	
		○	⊙	○	⊙	○	⊙	○	⊙
7,5	○○			4,28*	4,28*				
	⊥ℓ			4,28*	4,28*				
6,0	○○			3,79*	3,79*	3,46*	2,87		
	⊥ℓ			3,79*	3,79*	3,46*	3,46*		
4,5	○○			3,99*	3,99*	3,81*	2,89		
	⊥ℓ			3,99*	3,99*	3,81*	3,81*		
3,0	○○	3,97*	3,97*	4,64*	4,24	4,04*	2,84		
	⊥ℓ	3,97*	3,97*	4,64*	4,64*	4,04*	4,04*		
1,5	○○	7,86*	7,31	5,45*	4,08	4,26	2,77	2,66*	2,13
	⊥ℓ	7,86*	7,86*	5,45*	5,45*	4,36*	4,36*	2,66*	2,66*
0	○○	9,06*	6,99	6,00*	3,94	4,17	2,71		
	⊥ℓ	9,06*	9,06*	6,00*	6,00*	4,52*	4,45		
-1,5	○○	8,82*	6,88	5,89*	3,88	4,09*	2,69		
	⊥ℓ	8,82*	8,82*	5,89*	5,89*	4,09*	4,09*		

○ LIFTING CAPACITIES ON 360° WITHOUT SAFETY FACTOR

⊙ LIFTING CAPACITIES ON 360° ACCORDING WITH ISO 10567

\*= HYDRAULIC

LIMIT LIFTING CAPACITIES ARE ON HOOK WITHOUT GRABS, MACHINE STATIC, LEVEL SOLID GROUND, WITH AXLE LOCKED.

**WORKING DIAGRAM**

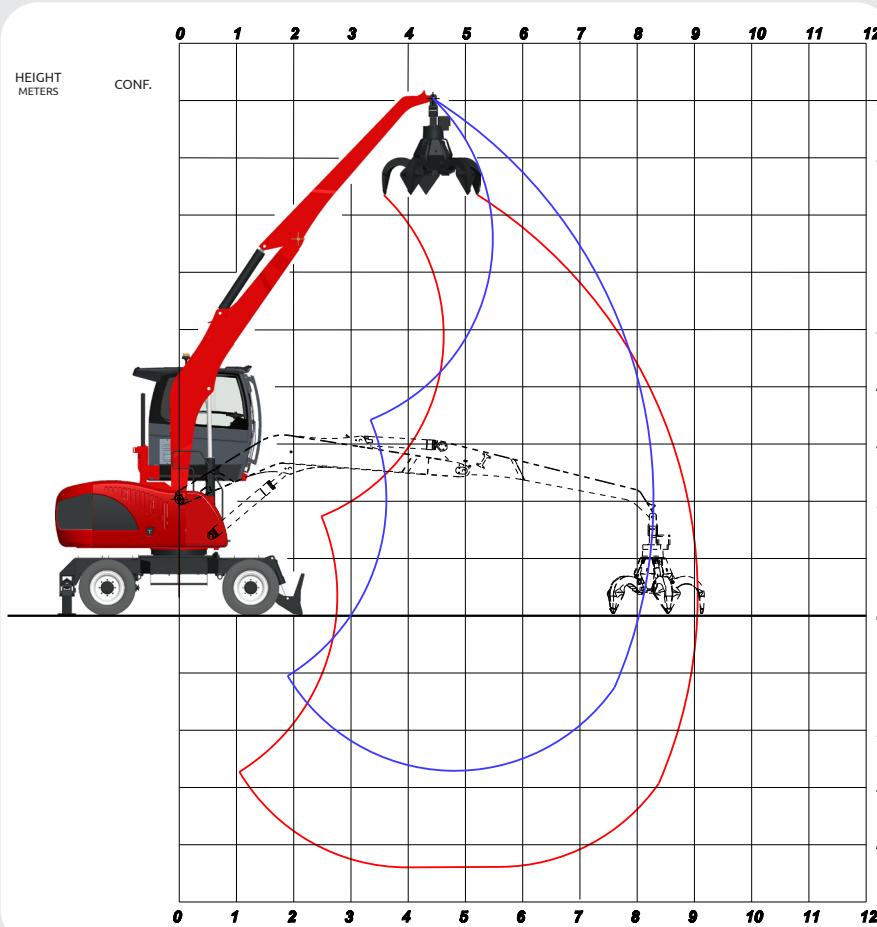

**AF8:**  
Gooseneck boom  
5,00 m

Industrial stick  
3,40 m

**OPERATING WEIGHT:**

**18.000 kg**

OPERATING WEIGHT WITH FRONT BLADE,  
REAR OUTRIGGERS, SOLID RUBBER TYRES,  
GOOSENECK BOOM 5,00 m,  
INDUSTRIAL STICK 3,4 m,  
RV 320 ORANGE PEEL GRAB WITH ROTATOR.

**LIFTING CAPACITIES TONS**

LIFTING RANGE (m)

HEIGHT METERS	CONF.	4,0		5,5		7,0		8,2	
		○	⊙	○	⊙	○	⊙	○	⊙
7,0	○○			3,37*	3,30				
	┌┐			3,37*	3,37*				
6,0	○○			3,30*	3,30*	3,20*	2,30		
	┌┐			3,30*	3,30*	3,20*	3,20*		
4,5	○○			3,54*	3,24	3,22*	2,29		
	┌┐			3,54*	3,54*	3,22*	3,22*		
3,0	○○	5,01*	4,86	3,96*	3,12	3,40*	2,24		
	┌┐	5,01*	5,01*	3,96*	3,96*	3,40*	3,40*		
1,5	○○	5,97*	4,57	4,40*	2,99	3,36	2,18	2,72	1,77
	┌┐	5,97*	5,97*	4,40*	4,40*	3,59*	3,59*	3,13*	3,10
0	○○	6,48*	4,39	4,46	2,90	3,28	2,13		
	┌┐	6,48*	6,48*	4,68*	4,68*	3,68*	3,68*		
-1,5	○○	6,38*	4,32	4,39	2,85	3,26	2,12		
	┌┐	6,38*	6,38*	4,63*	4,63*	3,47*	3,47*		

○ LIFTING CAPACITIES ON 360° WITHOUT SAFETY FACTOR

⊙ LIFTING CAPACITIES ON 360° ACCORDING WITH ISO 10567

\*= HYDRAULIC

LIMIT LIFTING CAPACITIES ARE ON HOOK WITHOUT GRABS, MACHINE STATIC, LEVEL SOLID GROUND, WITH AXLE LOCKED.

## WORKING DIAGRAM

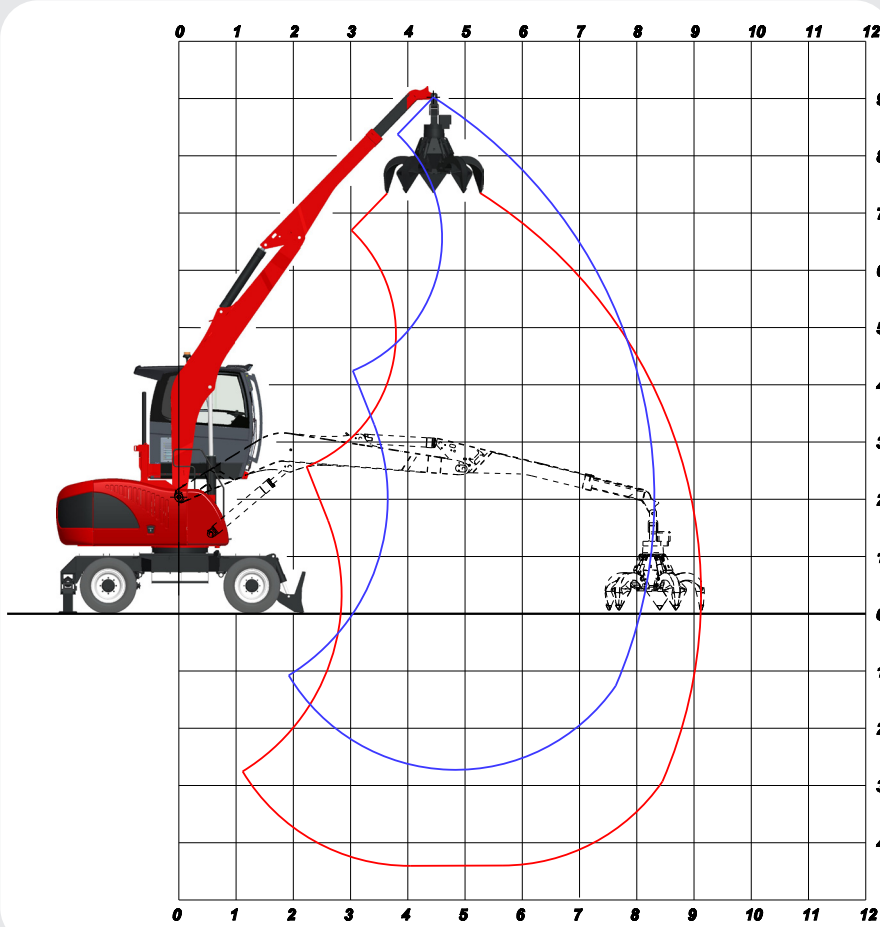

**AT8:**  
Gooseneck boom  
5,00 m

Telescopic stick  
2,50 - 3,40 m

**OPERATING WEIGHT:**

**18.200 kg**

OPERATING WEIGHT WITH FRONT BLADE,  
REAR OUTRIGGERS, SOLID RUBBER TYRES,  
GOOSENECK BOOM 5,00 m,  
TELESCOPIC STICK,  
RV 320 ORANGE PEEL GRAB WITH ROTATOR.

## LIFTING CAPACITIES TONS

LIFTING RANGE (m)

HEIGHT METERS	CONF.	4,0		5,5		7,0		8,2	
		○	⊙	○	⊙	○	⊙	○	⊙
7,0	○○			3,37*	3,30				
	┌┐			3,37*	3,37*				
6,0	○○			3,30*	3,30*	3,20*	2,30		
	┌┐			3,30*	3,30*	3,20*	3,20*		
4,5	○○			3,54*	3,24	3,22*	2,29		
	┌┐			3,54*	3,54*	3,22*	3,22*		
3,0	○○	5,01*	4,86	3,96*	3,12	3,40*	2,24		
	┌┐	5,01*	5,01*	3,96*	3,96*	3,40*	3,40*		
1,5	○○	5,97*	4,57	4,40*	2,99	3,36	2,18	2,72	1,77
	┌┐	5,97*	5,97*	4,40*	4,40*	3,59*	3,59*	3,13*	3,10
0	○○	6,48*	4,39	4,46	2,90	3,28	2,13		
	┌┐	6,48*	6,48*	4,68*	4,68*	3,68*	3,68*		
-1,5	○○	6,38*	4,32	4,39	2,85	3,26	2,12		
	┌┐	6,38*	6,38*	4,63*	4,63*	3,47*	3,47*		

○ LIFTING CAPACITIES ON 360° WITHOUT SAFETY FACTOR

⊙ LIFTING CAPACITIES ON 360° ACCORDING WITH ISO 10567

\*= HYDRAULIC

LIMIT LIFTING CAPACITIES ARE ON HOOK WITHOUT GRABS, MACHINE STATIC, LEVEL SOLID GROUND, WITH AXLE LOCKED.

**WORKING DIAGRAM**

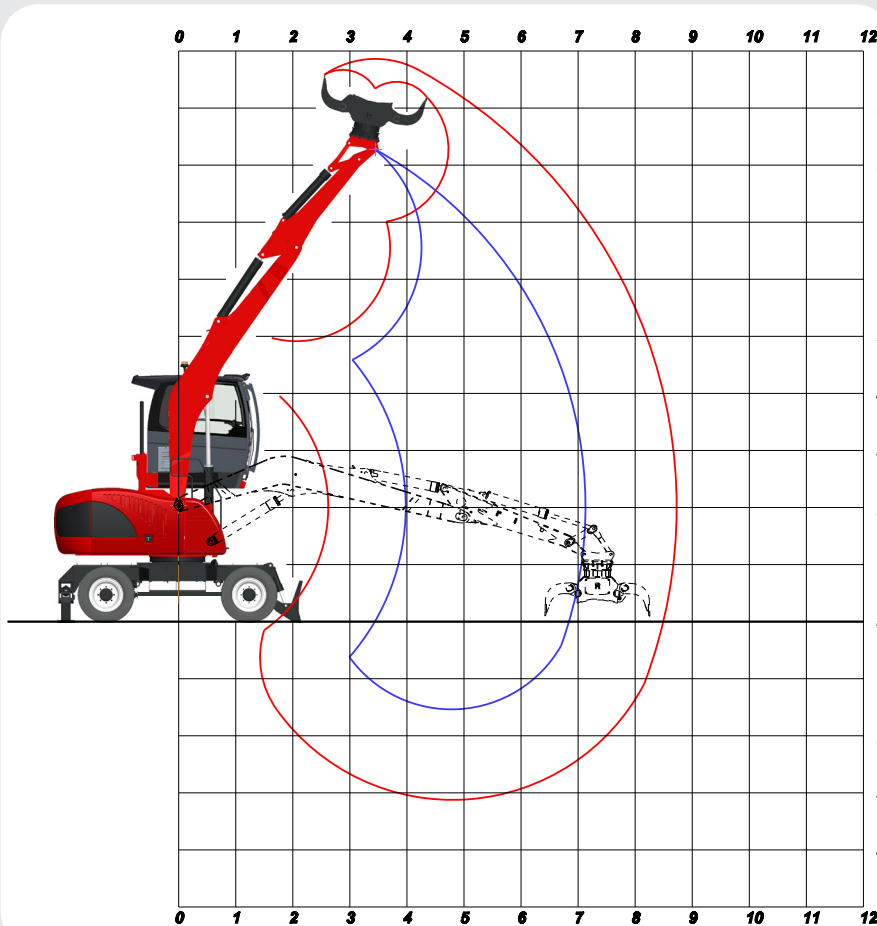

**AS8:**  
Gooseneck boom  
5,00 m

Selector arm  
2,20 m

**OPERATING WEIGHT:**

**17.800 kg**

OPERATING WEIGHT WITH FRONT BLADE,  
REAR OUTRIGGERS, SOLID RUBBER TYRES,  
GOOSENECK BOOM 5,00 m,  
SELECTOR ARM 2,2 m,  
RS 501X SELECTOR GRAB WITH ROTATOR.

**LIFTING CAPACITIES TONS**

LIFTING RANGE (m)

HEIGHT METERS	CONF.	4,0		5,5		7,0		7,1	
		○	⊙	○	⊙	○	⊙	○	⊙
6,0	○○			3,96*	3,02				
	┘┘			3,96*	3,96*				
4,5	○○	4,99*	4,75	4,07*	2,97				
	┘┘	4,99*	4,99*	4,07*	4,07*				
3,0	○○	5,91*	4,48	4,41*	2,87	3,13	2,03		
	┘┘	5,91*	5,91*	4,41*	4,41*	3,68*	3,68		
1,5	○○	6,57	4,27	4,27	2,77	3,08	2,00	3,02	1,96
	┘┘	6,59*	6,59*	4,71*	4,71*	3,69*	3,64	3,62*	3,57
0	○○	6,44	4,18	4,18	2,72				
	┘┘	6,59*	6,59*	4,74*	4,74*				
-1,0	○○	6,19*	4,18	4,17	2,71				
	┘┘	6,19*	6,19*	4,47*	4,47*				

○ LIFTING CAPACITIES ON 360° WITHOUT SAFETY FACTOR

⊙ LIFTING CAPACITIES ON 360° ACCORDING WITH ISO 10567

\*= HYDRAULIC

LIMIT LIFTING CAPACITIES ARE ON HOOK WITHOUT GRABS, MACHINE STATIC, LEVEL SOLID GROUND, WITH AXLE LOCKED.

# DIMENSIONS

**AT7**

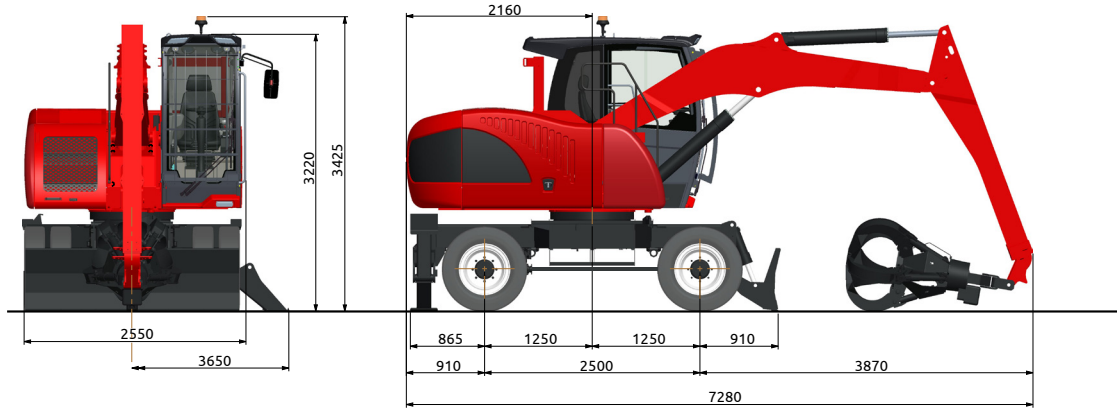

**AF8**

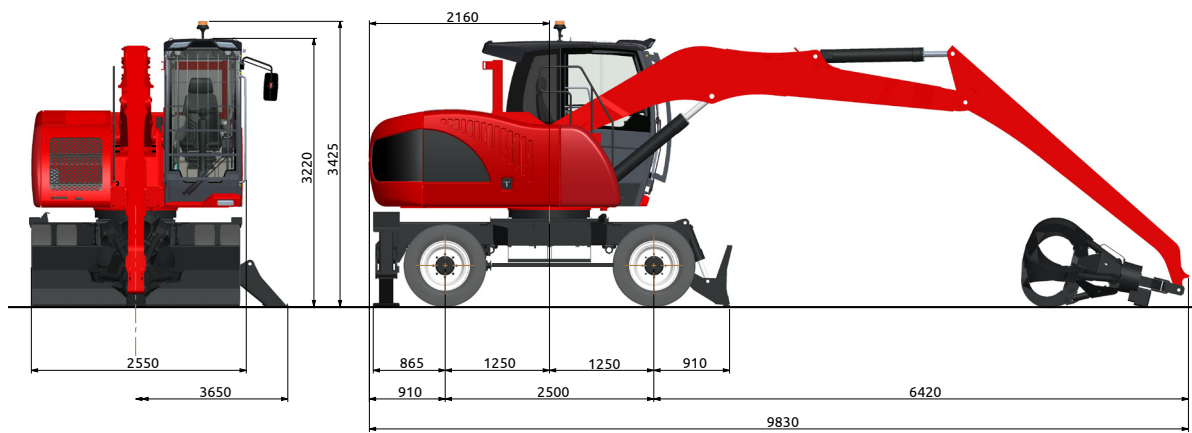

**AT8**

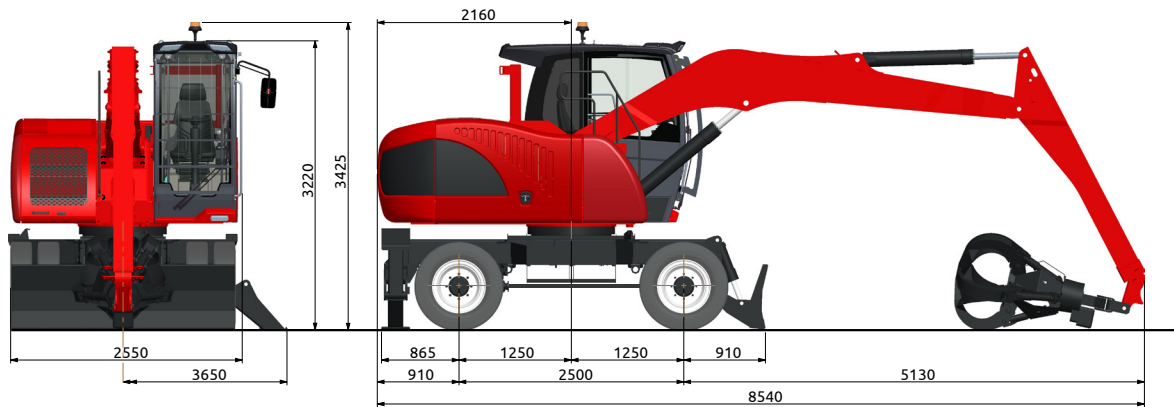

**AS8**

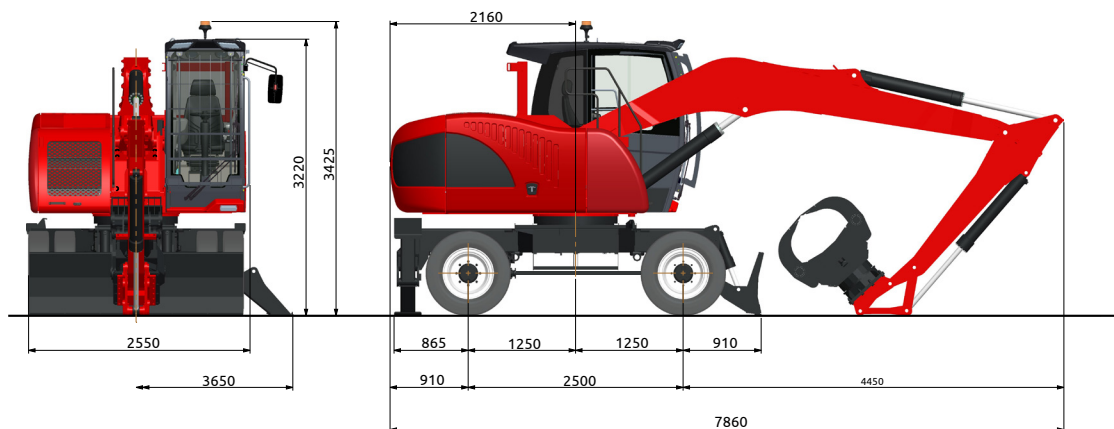

# ACCESSORIES

ACCESSORIES	STANDARD	OPTIONAL
- N° 8 TWINNED SOLID RUBBER TYRES 9.00 x 20 WITH SPACER RUBBER RINGS	•	
- STEERING ON JOYSTICK		•
- SELF LUBRICATING ANTI FRICTION BUSHES ON BLADE, OUTRIGGERS AND PARALLELOGRAM ELEVATING CAB.	•	
- MANUAL GREASING SYSTEM FOR THE STEERING AXLE	•	
- GEAR AND CARDAN JOINT PROTECTION		•
- VARIABLE DISPLACEMENT TRAVEL MOTOR		•
- WIDENINGS FOR FRONT DOZER BLADE		•
- TOWING HOOK		•
- HYDRAULIC VERTICAL RAISING CAB	•	
- HYDRAULIC PARALLELOGRAM RAISING CAB		•
- OPERATOR SEAT WITH PNEUMATIC SUSPENSION AND HEATING DEVICE	•	
- SAFETY SEAT BELT	•	
- AUTOMATIC AIR-CONDITIONING SYSTEM	•	
- AIR-CONDITIONING FILTER WITH ACTIVATED CHARCOAL		•
- RADIO WITH BLUETOOTH®		•
- WEIGHTING SYSTEM		•
- ANTI-THEFT IMMOBILIZER DEVICE		•
- THREE WORKING LED LIGHTS ON THE CABIN	•	
- FRONT AND ROOF WINDOW PROTECTION	•	
- TOTAL PROTECTION FOR THE CABIN		•
- AUTOMATIC GREASING SYSTEM FOR THE UPPERSTRUCTURE AND SLEW RING	•	
- THERMOSTATIC AUTOMATIC REVERSIBLE FAN	•	
- GENERATOR SYSTEM		•
- ADDITIONAL HEATING SYSTEM FOR COLD WEATHER COUNTRIES		•
- CAMERA WITH 7" COLOURED DISPLAY INTO THE CABIN		•
- FUEL AND HYDRAULIC OIL REFILLING PUMPS		•
- SOLIDA REMOTE MONITORING (SOLMEC LINK DATA)	•	
- TWO WORKING LED LIGHTS ON STICK		•
- SAFETY VALVES ON ALL CYLINDERS	•	
- SELF LEARNING DIPPER PROXIMITY AND HEIGHT LIMITER.	•	
- OVERLOAD WARNING DEVICE	•	
- LOCKING ARCH FOR LONG LOGS ON BOOM AND/OR STICK		•

## SOLMEC QUICK COUPLER

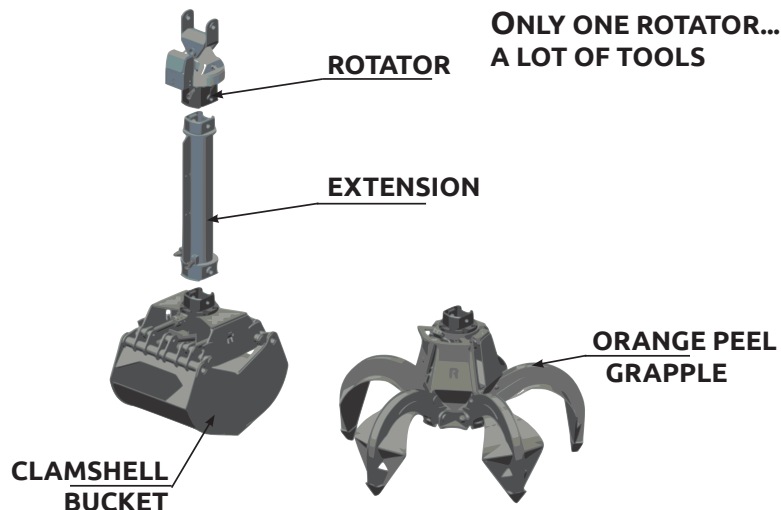

# TECHNICAL DATA EXP 5015

## DIESEL ENGINE

TCD 3.6 L4 T5 – TIER 5 (Stage V) – Ecological with catalytic converter DVERT® and electronically controlled injection - Particulate filter and AdBlue® - 4 strokes - 4 cylinders in-line - turbocharged with intercooler - common rail - direct injection - water cooled - electric starting system 24 V

Displacement:	3600cm <sup>3</sup>
Power:	85 kW (116 HP) @ 2100 rpm
Max torque:	460 Nm @ 1600 rpm
Tank Capacity:	220 l
AdBlue® tank capacity:	15 l

## HYDRAULIC SYSTEM

Open circuit LOAD SENSING with variable displacement axial piston pump with oil flow adjustment according to the load requirements, 4 power levels selectable from the dashboard, distributor block composed by 7 elements electro hydraulics, with high pressure control valves and antishock valves on each element.

Max. flow:	210 l/min
Max. Pressure:	300 bar
Hydraulic tank capacity:	200 l
Hydraulic circuit capacity:	250 l

Additional pumps for auxiliary services.

Hydraulic oil cooling by means aluminium large mesh heat exchanger combined with engine radiator. Automatic reversible fan for radiator cleaning.

## TRAVEL

Hydrostatic with 4 wheel drive by means of a variable displacement hydraulic axial piston motor mounted on a two speed gearbox hydraulically operated from the cab coupled to the rear axle.

Travel controlled by two separate pedals (one for each travelling direction).

Travel speed (in both directions)

Working speed:	from 0 to 5 km/h
Travel speed:	from 0 to 12 km/h

Differential axles 2,50 m wide with planetary reduction gears on the hubs. Braking valve integrated on the hydraulic motor.

## STEERING

Hydraulic steering system powered by an independent pump. The front floating steering axle can be hydraulically locked from the cabin in any position.

## TYRES

n° 8 twinned solid rubber tyres 9.00x20 with spacer rings  
n° 8 twinned tyres 9.00x20 - 16PR (as option).

## BRAKES

**SERVICE BRAKES:** Acting on the transmission using the self-braking characteristic of the travel hydrostatic system.

**PARKING AND EMERGENCY BRAKES:** Negative type with multiple discs oil bath on the rear axle and electro-hydraulic control for release.

## SWING SYSTEM

Unlimited rotation in both directions by means of an axial piston hydraulic motor with integrated control valve, splined to a planetary reduction unit with oil bath gears. High diameter double row ball bearing ring with internal teeth. Automatic greasing system

Max rotation speed:	7 rpm
Tail rotation radius:	2,25 m

## OPERATOR'S CAB

Hydraulically operated raising driver's cab mounted on a parallelogram linkage installed on silent block with large windows of tinted heat resistant safety glass; lateral opening window, upper and front glasses with safety grids and wipers. Winter heating and automatic air conditioned installed as standard with adjustable outlet. Radio preset.

Operator's seat with shock absorbing suspension, headrest, lumbar support, belt winder, electric seat heating device and armrests adjustable height and angle. Many possibilities of adjustment according to operator's weight and size.

## INSTRUMENTATION

Consists of a coloured display on the dashboard, includes: Engine speed indicator, fuel level, water thermometer, hour counter, hydraulic oil temperature, Volt, oil engine pressure, fuel consumption, load rate of the engine, engine diagnostics, and maintenance program.

Warning lights showing: air cleaner and oil filter clogging, park brake, brakes failure, lights, hydraulic oil low level, urea level, particulate filter regeneration, etc...

## CONTROLS

N° 2 electronic controlled joysticks to carry out the main four operations integrated with the armrests.

Electronic proportional rollers for front blade and/or outriggers and telescopic selector arm and/or grab rotator.

Electro hydraulic devices for controlling hydraulic raising of the cab, parking brakes, front axle oscillation lock, gear box.

## ARMS

With reach from 7 to 9 metres. Dipper stick could be also telescopic or selector arm.

## SOUND LEVELS

### NOISE LIMIT

Directive	2000/14/CE
Directive	2005/88/CE
Regulation	2024/1208/UE

Sound pressure level at the operator's position: LpA 81 dB (A)

## ELECTROMAGNETIC COMPATIBILITY

(Dir. 2014/30/UE) - The machine complies with the specified limits for both emissions and immunity.

## OVERLOAD WARNING DEVICE

Machinery Directive 2006/42/EC

Device for monitoring the machine's stability based on the load being handled and its position. It provides hazard warnings via acoustic and visual signals and automatically inhibits machine movements when stability limits are reached. It also displays the lifted load and the maximum permissible load in any working position.

# ATTACHMENTS

## HYDRAULIC ROTATORS

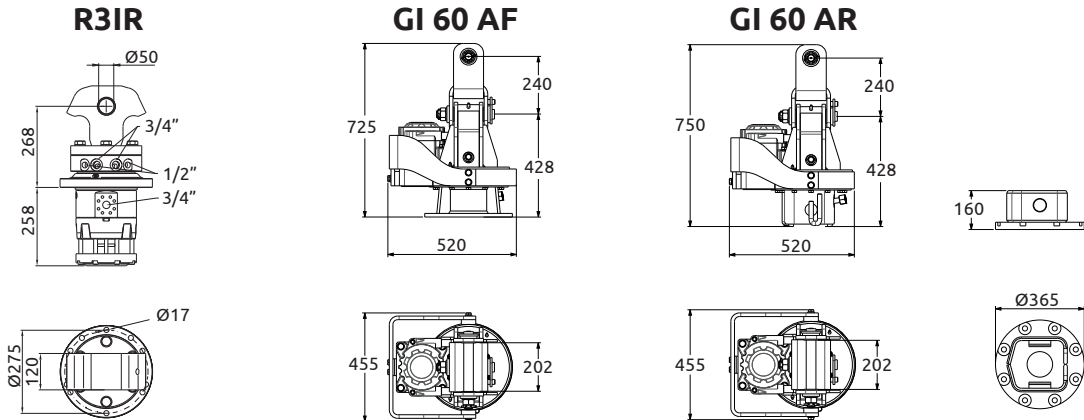

Model	Lifting capacity	Weight	Torque	Rotation max pressure	Rotation max flow	Attachement max pressure	Attachement max flow
R3IR	7 t	125 kg	210 daNm	190 bar	25 l/min	350 bar	-
GI 60 AF	5 t	200 kg	310 daNm	100 bar	32 l/min	300 bar	180 l/min
GI 60 AR	5 t	210 kg	310 daNm	100 bar	32 l/min	300 bar	180 l/min

## SPECIAL GRABS

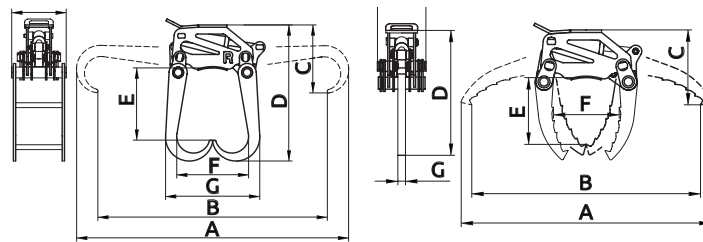

Model	Lifting capacity	Tine Force	Weight	Dimensions in mm							
				A	B	C	D	E	F	G	L
R51	2000 Kg	1540 kg	250 kg	2400	2020	600	1200	640	630	830	480
R58	1000 Kg	1940 kg	260 kg	1980	1810	590	990	530	520	60	380

## LIFTING HOOK

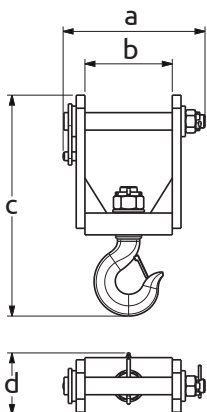

Model	Lifting capacity	Weight	Dimensions in mm			
			a	b	c	d
7.5 T	7.500 kg	30 kg	325	200	510	140

# ATTACHMENTS

## ORANGE PEEL GRABS FOR SCRAP

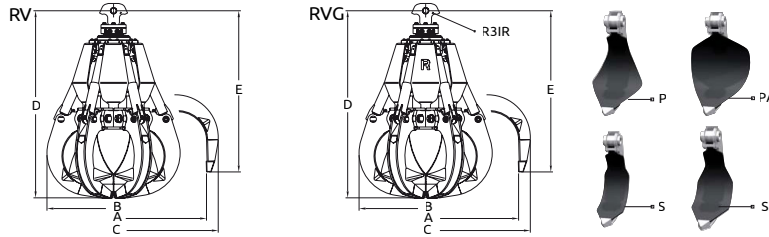

Model	Capacity	Tines	Weight	Nr of Tines	Dimensions in mm				
					A	B	C	D	E
RV320	320 l	P - PA - S - SL	620 kg	5	1680	1170	1800	1320	1100
RV320	320 l	P - PA - S - SL	680 kg	6	1680	1170	1800	1320	1100
RVGR320	320 l	P - PA - S - SL	740 kg	5	1680	1170	1800	1410	1190
RVGR320	320 l	P - PA - S - SL	800 kg	6	1680	1170	1800	1410	1190

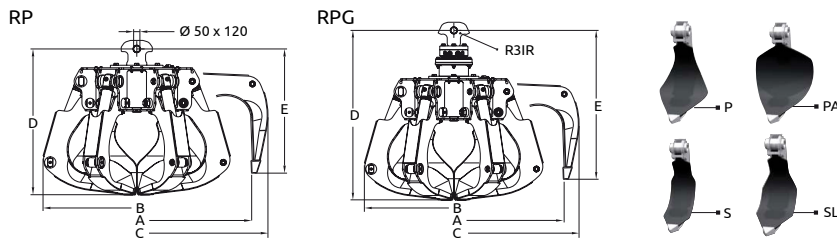

Model	Capacity	Tines	Weight	Nr of Tines	Dimensions in mm				
					A	B	C	D	E
RP380	380 l	P - PA - S - SL	700 kg	5	1780	1370	2015	1145	930
RP380	380 l	P - PA - S - SL	830 kg	6	1780	1370	2015	1145	930
RPG380	380 l	P - PA - S - SL	790 kg	5	1780	1370	2015	1410	1195
RPG380	380 l	P - PA - S - SL	920 kg	6	1780	1370	2015	1410	1195

## ORANGE PEEL GRABS FOR WASTE

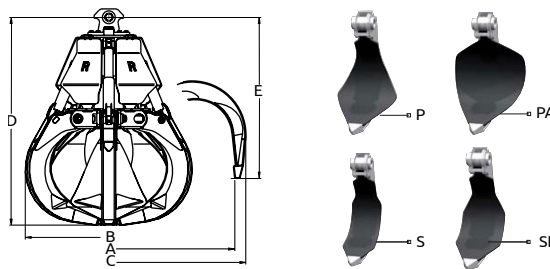

Model	Capacity	Tines	Weight	Nr of Tines	Dimensions in mm				
					A	B	C	D	E
RR560	560 l	P - PA - S - SL	660 kg	5	2000	1310	2110	1460	1110

## SELECTOR GRAB

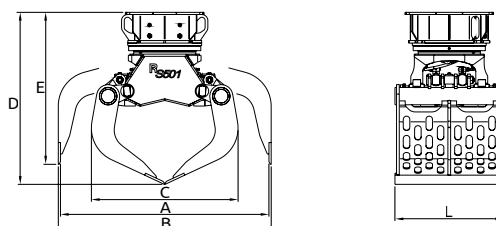

Model	Capacity	Tine Force	Weight	Dimensions in mm					
				A	B	C	D	E	L
RSG451X	320 l	3700 daN	800 kg	1800	1850	1160	1360	1220	700

# ATTACHMENTS

## LOGS GRAPPLES

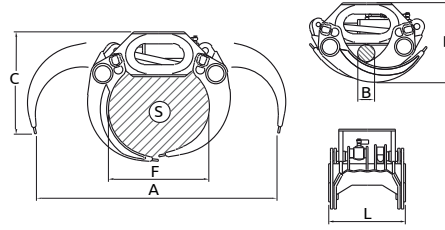

Model	Area	Lifting capacity	Weight	Dimensions in mm					
				A	B	C	D	L	F
SG 520 S-HD	0,52 m <sup>2</sup>	8000 kg	475 kg	2279	170	886	753	514	-
R50/401	0,40 m <sup>2</sup>	3000 kg	405 kg	1900	140	810	670	640	800
R50/604	0,60 m <sup>2</sup>	4000 kg	800 kg	2160	230	890	890	920	900

## CLAMSHELL BUCKETS

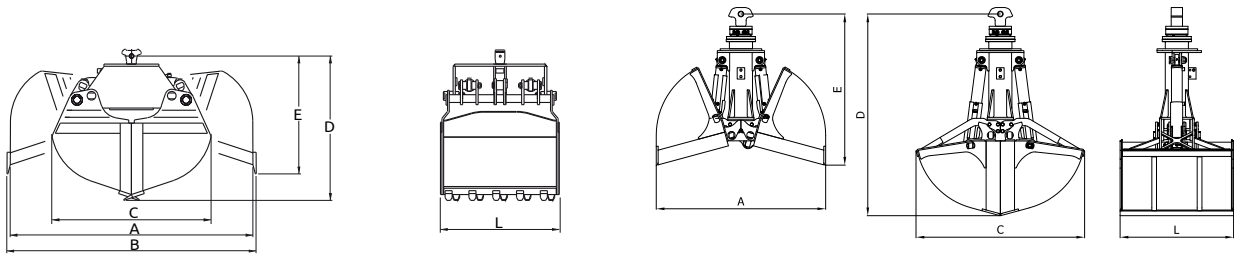

Model	Capacity	Tine Force	Weight	Dimensions in mm					
				A	B	C	D	E	L
R41/700	500 l	4400 daN	720 kg	1990	2070	1270	1230	1070	820
R41/1000	750 l	4060 daN	880 kg	2140	2220	1400	1320	1100	1020

## MAGNETS

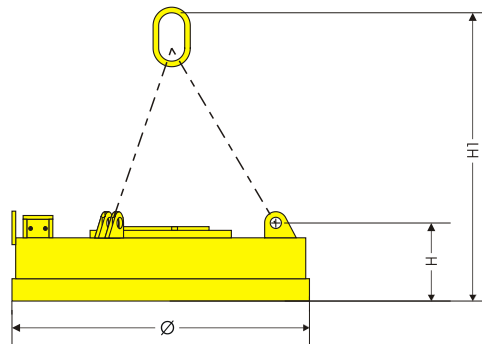

Model	Absorbed power at 20°	Nominal	Weight	Ø	H	H1	Hot tear strength (1) Δ= Ø300	Hot Lifting capacity (2)		Hot Lifting capacity (3)			
								Slabs or block	Drop Ball	Cast Iron Pigs	Scrap		
	kW	Vdc	kg	mm	mm	mm	kg	kg	kg	3A 2,2 ÷ 2,5 t/m <sup>3</sup>	24 1,9 ÷ 2,0 t/m <sup>3</sup>	40 0,8 ÷ 1,0 t/m <sup>3</sup>	
ECS 900	4	220	450	900	225	920	7900	3900	1380	160	150	130	70
MRS 850	4,5	220	480	860	280	975	8200	4100	1700	200	170	160	80

(1) Determined in accordance with VDE 0580 § 36

(2) Determined after 5 hours and an ambient temperature of 20°C in accordance with VDE 0580 § 36

(3) Determined in accordance with VDE 0580 § 44 2-6



The latest version of the brochure is available on the Solmec website.



Viale delle industrie, 9  
45100 ROVIGO - ITALY  
phone +39 0425 474833  
[www.solmec.it](http://www.solmec.it)  
[solmec@solmec.it](mailto:solmec@solmec.it)